

# Series TB-603 & TB-602

## *Handy Mini-Hoists lift Up to 1100 Lbs. Convenient Toolbox Storage*

The Yale/Budgit TB-603 & TB-602 *toolbox* hoists are the most compact ratchet lever hoists in the market, perform just like the larger models, *plus* come standard with these great features:

- Plated load chain is standard.
- Weston-type load brake.
- Rubber hand grip for better comfort and security.
- Lightweight design for ease of portability. Use in confined conditions with one-hand operation.
- Forged upper and lower hooks with latches standard.
- Impact resistant, all-steel frame, gear case and cover.
- Hardened link-type steel load chain for strength and long wear.
- Free wheeling feature serves to quickly attach the load.
- Metric rated.



**TB-603**  
**1100 Lb.**  
Capacity



**5 Ft.  
&  
10 Ft. Lifts**

**TB-602**  
**550 Lb.**  
Capacity



*The  
Uses are  
Endless  
Performs Just  
Like the Larger Hoists,  
but Small Enough to  
Fit in a Hard Hat*

### S P E C I F I C A T I O N S

Model TB-603 & TB-602

Capacity (Lbs.)	Capacity (Kg.)	Model Number	Product Code	Number of Chainfalls	Chain Dimensions d x t (In.)	Handle Length (In.)	Minimum Distance Between Hooks (In.)	Lift w/ One Full Lever Turn (In.)	Handle Pull @ W.L.L. (Lbs.)	Net Weight w/ standard Lift (Lbs.)
550	250	<b>TB-602</b>	0210	1	.16 x .47	6.300	9.45	3.15	56	6.0
1100	500	<b>TB-603</b>	0215	1	.16 x .47	6.375	11.125	1.57	78	7.0

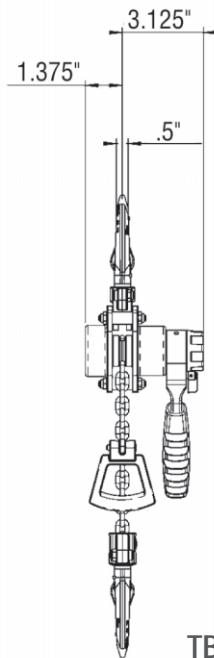
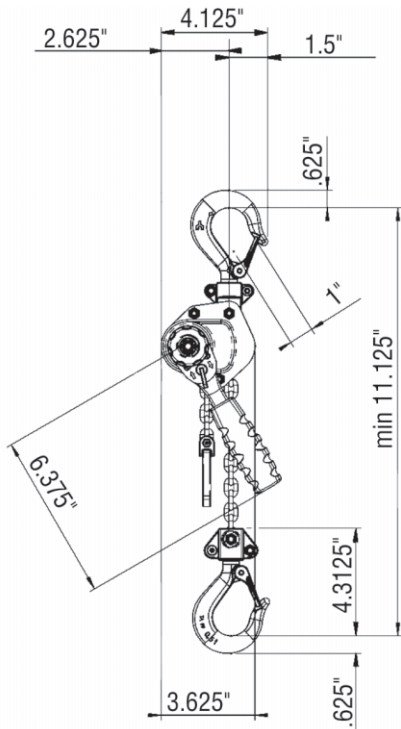

TB-603



DIMENSIONAL DRAWINGS

TB-602

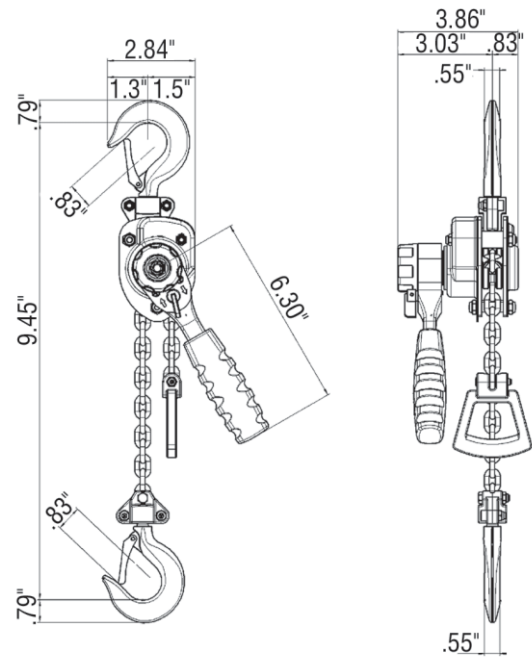

**⚠ WARNING**

**To Avoid Injury:**

- Do not exceed working load limit, load rating, or capacity.
- Do not use to lift people or loads over people.
- Read and follow all instructions.

**CORNERSTONE**  
MATERIAL HANDLING

1-877-611-2644 [www.cornerstonematerialhandling.com](http://www.cornerstonematerialhandling.com)