

Yale®

OPERATING & MAINTENANCE INSTRUCTIONS

WITH PARTS LIST

PUBLICATION PART NO. PSA-680

SHOP KING HOISTS

STEEL BODY LEVER HOIST/PULLER

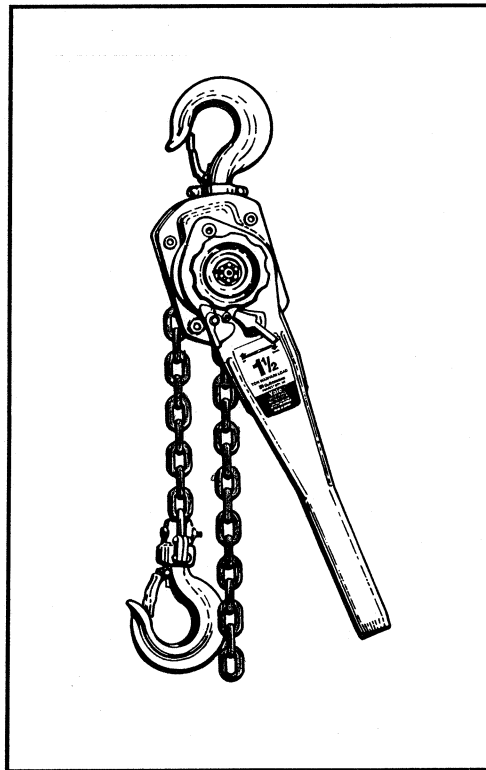

PSA SERIES

IMPORTANT — CAUTION

This manual contains important information for the correct installation, operation and maintenance of the equipment described herein. All persons involved in such installation, operation, and maintenance should be thoroughly familiar with the contents. To safeguard against the possibility of personal injury or property damage, follow the recommendations and instructions of this manual and keep it for further reference.

WARNING

The equipment shown in this manual is intended for industrial use only and should not be used to lift, support, or otherwise transport people.

 **Duff-Norton**

TABLE OF CONTENTS

		PAGE
SECTION I	INTRODUCTION	
1-1	General Information	3
1-2	Hoist Construction	3
1-3	Specifications	3
SECTION II	PREPARATION FOR USE	3
SECTION III	OPERATING INSTRUCTIONS	
3-1	Hoisting (Pulling) and Lowering	3
3-2	Free-Chaining	4
SECTION IV	OPERATING PRECAUTIONS	5
SECTION V	ROUTINE CARE, INSPECTION, AND MAINTENANCE	6
5-1	Care of Hoist	6
5-2	Inspection	6
5-3	Chain Inspection	6
5-4	Disassembly	7
5-5	Lubrication	7
5-6	Brake Assembly	7
5-7	Gear Assembly (3-ton and 6-ton only)	7
SECTION VI	TROUBLE-SHOOTING	
6-1	Trouble-shooting Chart	8
SECTION VII	PARTS LIST AND EXPLODED VIEW	
7-1	Repair Parts List	9
7-2	Exploded View	10 & 11

Warranty

Every hoist is thoroughly inspected and tested prior to shipment from the factory. Should any problems develop, return the complete hoist prepaid to Duff-Norton, Highway 1 North, Forrest City, AR 72335. If inspection reveals that the problem is caused by defective workmanship or material, repairs will be made without charge and the hoist will be returned, transportation prepaid.

This warranty does not apply where: (1) deterioration is caused by normal wear, abuse, improper or inadequate power supply, eccentric or side loading, overloading, chemical or abrasive actions, improper maintenance or excessive heat; (2) problems resulted from

repairs, modifications or alterations made by persons other than factory or Duff-Norton personnel; (3) the hoist has been abused or damaged as a result of an accident; (4) repair parts or accessories other than those supplied by Duff-Norton are used on the hoist. Equipment and accessories not of the seller's manufacture are warranted only to the extent that they are warranted by the manufacturer. EXCEPT AS STATED HEREIN, DUFF-NORTON MAKES NO OTHER WARRANTIES, EXPRESS OR IMPLIED, INCLUDING WARRANTIES OF MERCHANTABILITY AND FITNESS FOR A PARTICULAR PURPOSE.

SECTION I

INTRODUCTION

1-1. General Information

This manual provides information for the safe operation and maintenance of the Yale® Steel Body Lever Hoist/Puller. All persons operating or maintaining the hoist should be familiar with the information contained here. Adherence to the precautions, procedures, and maintenance practices described should ensure long, reliable operation.

1-2. Hoist Construction

The Steel Body Lever Hoist/Puller provides a compact, efficient means for accurately positioning heavy loads or for lifting freely suspended loads within its load rating. The large reversing lever and free-chain knob allow easy control, even with gloves, while the short handle and low handle effort allow use of the hoist in confined spaces.

1-3. SPECIFICATIONS

Model No.	Rated Load (lb)	Standard Lift (ft)	Pull On Lever to Lift Load (lb)	Hook Throat Opening with Latch (in)	Min. Distance Between Hooks (in)	Load Chain Diameter	Weight (lb)
PSA 3/4	1500	5, 10, 20	44	.83	11 1/2	1/4 in.	18
PSA 1 1/2	3000	5, 10, 20	48	1.19	14 1/4	5/16 in.	29
PSA 3	6000	5, 10, 20	75	1.55	18 1/2	10 mm	48
PSA 6	12000	5, 10, 20	82	1.89	24 7/16	10 mm	75

NOTE: Yale hoists meet the design and test requirements of all existing OSHA and ANSI Standards for Overhead Hoists.

SECTION II

PREPARATION FOR USE

2-1. When unpacking the hoist, inspect carefully for any damage that may have occurred during shipping. Check for loose, missing, or damaged parts.

2-2. Lubricate the chain along its entire length with SAE 30 oil.

2-3. When using the hoist to lift a load, be sure that all structures supporting the hoist are strong enough to support the full rated load of the hoist with a generous factor of safety.

SECTION III

OPERATING INSTRUCTIONS

3-1. Hoisting (Pulling) and Lowering

- a. When lifting or pulling a load, set the reversing lever to the UP position and move the handle in a clockwise direction (see Figure 3-A).
- b. To lower a suspended load, set the reversing lever to the DOWN position and move the handle in a counterclockwise direction (see Figure 3-B).

NOTE

With no load on the hoist, reciprocating the handle may result in only a back and forth movement of the chain, with no advancement of the hook. When this happens, the chain may be positioned by applying a light pull to the chain with the free hand, or by using the free-chain feature (paragraph 3-2).

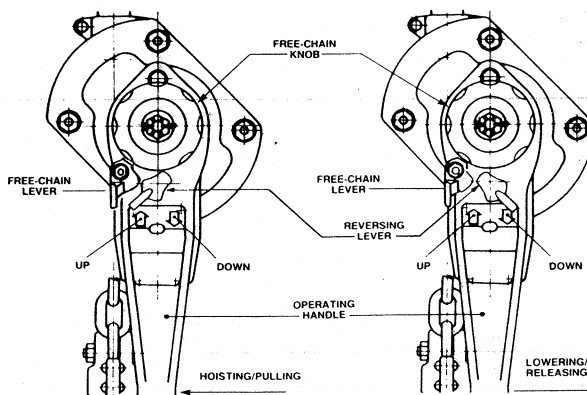

FIGURE 3-A.

FIGURE 3-B.

3-2. Free-Chaining

The free-chain feature allows the unloaded hook to be very quickly moved to the best position for attaching the load.

Never attempt to use the free-chain feature while there is any load on the hoist.

- a. Set the reversing lever to the Neutral position (see Figure 3-C).

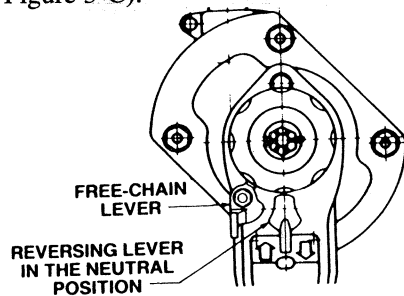

FIGURE 3-C.

- b. Release the free-chain lever by pushing it in the direction of the arrow (see Figure 3-D). Move the free-chain knob to the free-chaining position by turning the knob counterclockwise while pulling it out (see Figure 3-E). The free-chain knob should then be supported in the outer position by the check washer as shown in Figure 3-F.

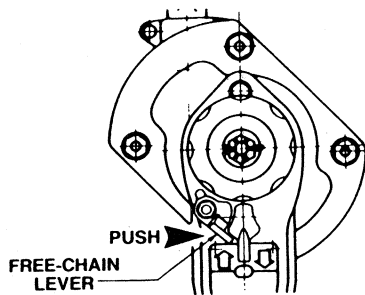

FIGURE 3-D.

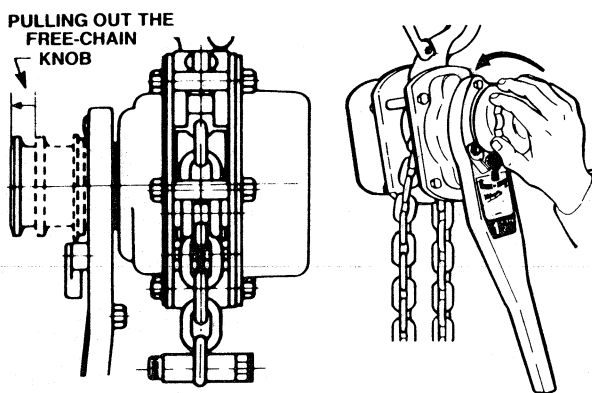

FIGURE 3-E.

- c. The chain should now be free to move to the desired position (Figure 3-G).
- d. To remove the hoist from the free-chaining mode, turn the free-chain knob counterclockwise until it moves back to the inward position.

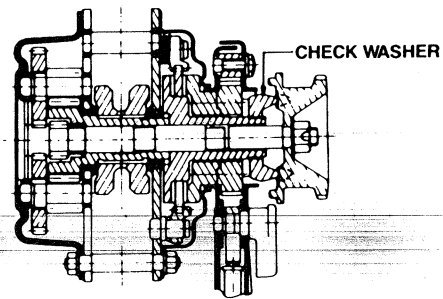

FIGURE 3-F.

Occasionally the knob may be hesitant to go completely back to the inward position. In this case, turn the knob clockwise until it is pushed completely in.

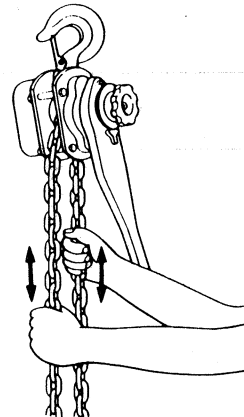

FIGURE 3-G.

- e. When the reversing lever is put into the UP or DOWN position, it should lock the free-chain lever as shown in Figure 3-H, which prevents the free-chain knob from being pulled out.

This is a safety feature that prevents the free-chain mechanism from being moved while the hoist is being operated.

CAUTION

Never attempt to load or operate the hoist when the free-chain knob is not in the fully inward position and locked by the free-chain lever.

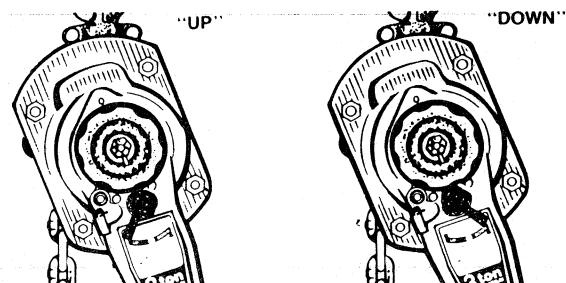

FIGURE 3-H.

SECTION IV

OPERATING PRECAUTIONS

4-1. Do not lift or pull more than the rated capacity of the hoist.

4-2. Do not use a handle extension (cheater bar). The hoist is designed to pull rated loads with low handle effort (see Specifications, paragraph 1-3). If a cheater bar seems necessary, the hoist is almost certainly overloaded.

4-3. Attaching the Load

- a. Be sure there are no twists in the load chain as it enters the hoist. This condition should be constantly checked on double chain hoists because it is possible for the load block to be "capsized" or flipped over one or more times, putting twist in the chain. The presence of a twist may not be obvious when the hook block is in the lowered position, but can cause serious chain binding when the hook is in its fully raised position.
- b. Do not side load the hoist. Always pull in a straight line between the hooks. The body of the hoist should not bear against its support. Figures 4-C through 4-E show examples of dangerous side loading.
- c. Never tip load the hook (Figure 4-A). Use attachments that will seat in the saddle of the hook (Figure 4-B).
- d. Make sure that slings and other rigging are in good condition and have sufficient capacity. Never wrap the hoist chain around a load (Figure 4-F).

4-4. Stand clear of the load at all times. The operator should have sufficient room to use the hoist without endangering himself.

CAUTION

DO NOT OPERATE THE HOIST FROM AN OFF-BALANCE POSITION. OPERATOR SHOULD HAVE FIRM FOOTING OR BE OTHERWISE SECURED BEFORE OPERATING THE HOIST.

4-5. Check the hoist each time it is used by lifting the load just clear of its supports and checking to be sure that the load is secure in the hook and that the hoist brake is holding the load without slipping.

4-6. Never jam the hook block into the bottom of the hoist or run the hook down until the slack chain is pulled tight.

4-7. Never attempt to free-chain the hoist with any load on the hook.

4-8. Do not leave a suspended load unattended.

4-9. Do not throw or drop the hoist, or drag it along the ground.

4-10. Do not use a damaged or malfunctioning hoist.

4-11. Lifting a load with two hoists is not recommended. If unavoidable, care must be taken that neither hoist is overloaded.

WARNING

DO NOT USE THE HOIST TO LIFT, SUPPORT OR OTHERWISE TRANSPORT PEOPLE.

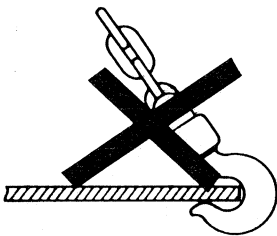

FIGURE 4-A.

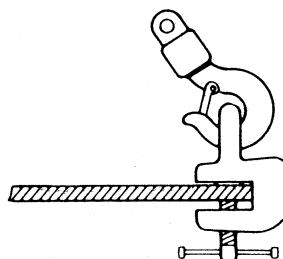

FIGURE 4-B.

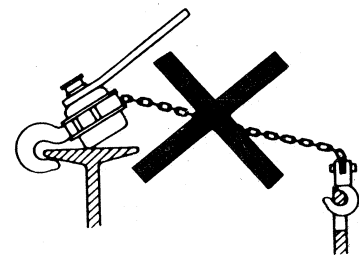

FIGURE 4-C.

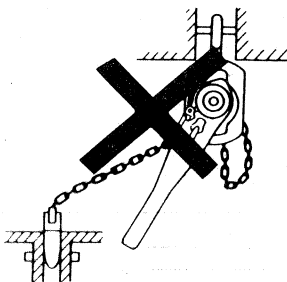

FIGURE 4-D.

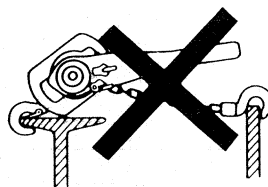

FIGURE 4-E.



FIGURE 4-F.

SECTION V.

ROUTINE CARE, INSPECTION, AND MAINTENANCE

5-1. Care of Hoist

- a. Never leave or store the hoist with the brake locked. Loosen the brake by operating the hoist as if lowering a load.
- b. Avoid leaving the hoist in a wet or corrosive environment. Clean and dry the hoist before storage whenever it has been exposed to dirt or water.
- c. Inspect the hoist for signs of wear, damage, or malfunctioning parts. Do not return a defective hoist to a storage area without clearly marking it as defective.

5-2. Inspection

Periodic inspection and lubrication is important to ensure long and satisfactory operation of the hoist. The recommended inspection intervals indicated in Table 5-1 are based on intermittent operation. The user should reduce or extend his inspection intervals based on usage and individual experience.

The free-chain lever is a safety device to prevent free-chaining while there is any load on the hoist. Be sure that the free-chain lever moves freely and that its pawl always locks the flange of the free-chain knob.

5-3. Chain Inspection

Hang a light load on the hoist to pull the chain taut and use calipers to check the chain for wear or stretch, as shown in Figure 5-A. Replace any chain showing damage, or wear beyond the wear limit shown in Table 5-2.

CAUTION

If chain is worn or otherwise damaged, replace the entire chain with new chain supplied by the hoist manufacturer. Do not substitute. Do not attempt to weld chain or use connecting links.

TABLE 5-1. INSPECTION SCHEDULE

Interval	Inspection
Daily	<ol style="list-style-type: none"> a. Check hooks, and hook latches for deformation or cracks. Twisted hooks or hooks with throat openings larger than the limits listed in Figure 5-C should be replaced. b. Check chain for wear and twist. c. Check operating handle for cracks or bending. d. Check brake for drift.
Quarterly	<ol style="list-style-type: none"> a. Check for loose screws, nuts, etc. b. Check load sprocket for wear.
Annually	<ol style="list-style-type: none"> a. Inspect for worn, cracked or distorted gears, bearings, pawl, pawl spring, ratchet, shafts and chain fastening bolt. b. Check for worn brake discs. Replace any disc less than .078" thick. c. Inspect hooks for cracks using magnetic particle or similar test. d. Clean chain in kerosene or other non-corrosive solvent and inspect for wear, nicks, or distortion of any kind.

**TABLE 5-2.
LOAD CHAIN DIMENSIONS**

Rated Load (lb)	Diameter (in)	Standard (in)	LIMIT (in)
1500	.250	7.520	7.669
3000	.312	9.528	9.717
6000	.394	11.929	12.169
12000	.394	11.929	12.169

(10 link dimension)

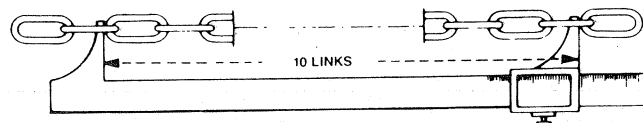

FIGURE 5-A.

5-4. Disassembly

Disassembly is straightforward. Note the location and orientation of the various parts.

5-5. Lubrication

- Good lubrication is vital to long chain life. The chain should be kept well oiled with SAE 30 weight oil. Be sure that the oil is worked into the area between the links.
- If the hoist is disassembled for inspection or repair, relubricate the moving parts according to Table 5-3.

CAUTION

The brake surfaces must be kept free of any trace of oil or grease. Apply lubricant sparingly to the parts near the brake to avoid oil contamination of the brake.

**TABLE 5-3.
RECOMMENDED LUBRICANTS**

Part	Lubricant
Gears, bearings, pawl pivot pin, guide roller pin, hook shanks.	Any good quality NLGI #2 grease
Chain	SAE 30 weight oil
Brake parts, ratchet teeth.	Do Not Lubricate

5-6. Brake Assembly

- Remove any foreign matter found on the braking surfaces. Replace brake discs worn to less than .078" thick.
- Assemble all parts on shaft up to the check-washer. Be sure the disc nut is screwed down tight.
- Insert the check-washer so that the clearance "a" (Figure 5-B is equal to or greater than the clearance "b.")

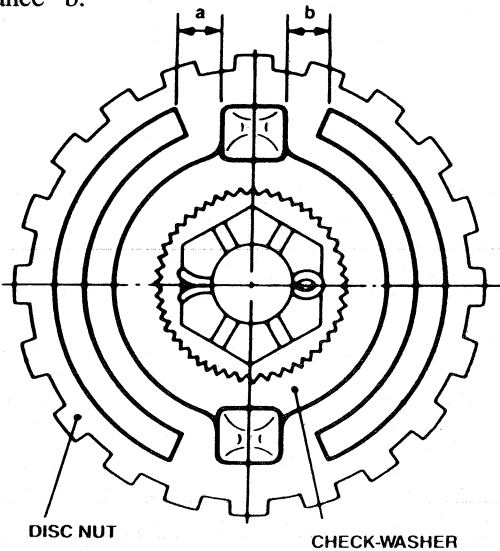

FIGURE 5-B.

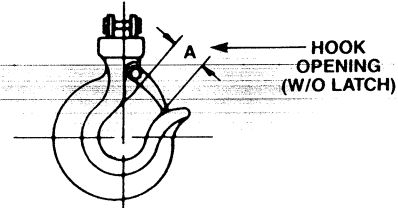

FIGURE 5-C.

HOOK DIMENSIONS (Opening)

Capacity (ton)	A Standard Size (in)	A LIMIT (in)
3/4	.984	1.132
1 1/2	1.339	1.540
3	1.772	2.038
6	2.047	2.354

NOTE

The dimension A is the maximum permissible dimension of the hooks, which is about 15% wider than the standard hook opening.

5-7. Gear Assembly (3 and 6-ton only)

The twin gears each have an "O" stamped on them which is used as a timing mark. The twin gears must be installed so that the timing marks both point to exactly the 9 o'clock position at the same time (see Figure 5-D). Be sure that the snap ring (item no. 102) is securely placed in the load gear groove after assembling item no. 20, handle-side plate.

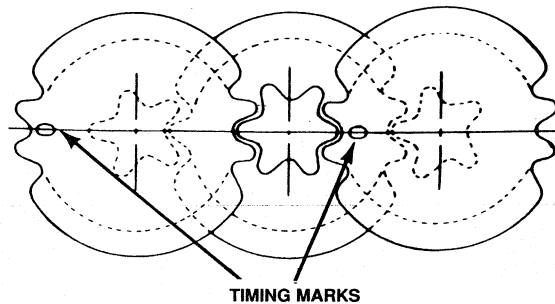

FIGURE 5-D.

SECTION VI

TROUBLE-SHOOTING

6-1. Trouble-shooting Chart

Condition	Cause	How to Repair
Pinion shaft does not return to position after free-chaining.	1. Wear of the spline section of the pinion shaft.	Replace with new parts.
	2. Deformation or damage of the return spring.	Replace with new parts.
	3. Mechanism fouled with foreign matter such as dirt and dust.	Disassemble and clean.
Slip caused by ineffective braking.	<ol style="list-style-type: none"> 1. Worn out friction discs. 2. Oil on the braking surface. 3. Incorrect assembly of the brake system. 	Replace with new ones. Disassemble and clean. Assemble correctly referring to page 9.
Load dropped while lowering.	<ol style="list-style-type: none"> 1. Damaged friction discs. 2. Foreign matter in the braking system. 	Replace with new ones. Disassemble and clean.
Jammed operating handle.	Over-tightening of the brake.	Operate the lever hoist as if lowering a load.
Noises during hoisting and lowering operation.	Wear or deformation of the load chain and load sheave.	Replace with new parts.
Operating handle becomes difficult to operate during lifting or lowering operation.	<ol style="list-style-type: none"> 1. Over-hoisting or over-lowering. 2. Twist in the load chain causing it to get caught between load sheave and load chain guide.. 	Operate the hoist in opposite direction. Operate the hoist in opposite direction and remove the twist from the load chain.

SECTION VII

PARTS LIST AND EXPLODED VIEW

7-1. Repair Parts List

The below listed parts are available for repair of LSB Series hoist/pullers. Damage or excessive wear to other parts require replacement of entire hoist/puller.

To order parts, specify hoist serial number, model number and part number from table below.

DESCRIPTION	CONSISTING OF ITEM NO.	PART NUMBER			
		MODEL NO. PSA-3/4	MODEL NO. PSA-1 1/2	MODEL NO. PSA-3	MODEL NO. PSA-6
Disc Hub	8	LSB-35	LSB-35-1	LSB-35-2	LSB-12000
Output Gear Kit	4N, 102	LSB-405N	LSB-405-1N	—	—
Output Gear Kit	4S, 102	—	—	LSB-405-2	LSB-405-2
Top Hook Assembly	48	LSB-20A	LSB-20-1A	LSB-20-2A	LSB-20-3A
Chain Fastening Bolt	124, 125	LSB-700	LSB-700-1	LSB-700-2	LSB-700-2
Load Sheave	5N	LSB-16N	LSB-16-1N	—	—
Load Sheave	5S	—	—	LSB-16-2	LSB-16-2
Latch Kit	74	LSB-123A	LSB-123-1A	LSB-123-2A	LSB-123-3A
Pawl Kit	7, 9, 103	LSB-25K	LSB-25-1K	LSB-25-2K	LSB-25-2K
Bottom Hook Assembly	53, 124, 125	LSB-50A	LSB-50-1A	LSB-50-2A	LSB-50-3A
Brake Kit	103, 104, 105	LSB-580K	LSB-580-1K	LSB-580-2K	LSB-580-2K
Parts Kit	41, 126, 119, 120, 121	LSB-910K	LSB-910-1K	LSB-910-2K	LSB-910-2K
Gear	2	LSB-400	LSB-400-1	LSB-400-2	LSB-400-2
Disc Nut Kit	23, 136	LSB-34K	LSB-34K	LSB-34K	LSB-34K
Spring Shaft Kit	30, 31, 116	LSB-340K	LSB-340K	LSB-340K	LSB-340K
Free-chain Lever Kit	60, 137, 138, 139	LSB-32K	LSB-32K	LSB-32K	LSB-32K
Operating Handle Kit	24, 26, 34-1, 110, 111, 112, 196	LSB-1A	LSB-1-1A	LSB-1-2A	LSB-1-3A
Pinton Shaft Kit	1, 101, 59	LSB-401K	LSB-401-1K	LSB-401-2K	LSB-401-2K
Load Chain	6	LSB-19	LSB-19-1	LSB-19-2	LSB-19-2
Chain Guide Kit	13, 14, (12 for 3 & 6 Ton)	LSB-36K	LSB-36-1K	LSB-36-2K	LSB-36-2K
Gear Cover	37	LSB-31	LSB-31-1	LSB-31-2	LSB-31-2
Ratchet Cover	40	LSB-11	LSB-11-1	LSB-11-2	LSB-11-2
Sheave And Pin Kit	56, 57	—	—	—	LSB-28K
Bottom Block Kit	34, 112, 55, 58	—	—	—	LSB-28-1K
Gear Side Plate	18	LSB-18	LSB-18-1	LSB-18-2	LSB-18-2
Handle Side Plate	20	LSB-17	LSB-17-1	LSB-17-2	LSB-17-2
Chain Stripper	16, 15	—	—	LSB-37	LSB-37
Yoke Pin	51	LSB-130	LSB-130-1	LSB-130-2	LSB-130-2
Stay Bolt Kit	21, 107, 106	LSB-15	LSB-151-1	LSB-15-2	LSB-15-2
Overtravel Restraint	22	LSB-75	LSB-75-1	LSB-75-2	LSB-75-2
Disc Nut Washer	10	LSB-298	LSB-298-1	LSB-298-2	LSB-298-2
Free Chain Knob	42	LSB-100	LSB-100-1	LSB-100-2	LSB-100-2
Warning Decal	195	LSB-687	LSB-687	LSB-687	LSB-687
Name Plate	196	LSB-674-1	LSB-674-2	LSB-674-3	LSB-674-4
6474314	01 thru 04	647431401	647431402	647431403	647431404

JH H 5009 T
LH H 5009 T

7-2. Exploded View

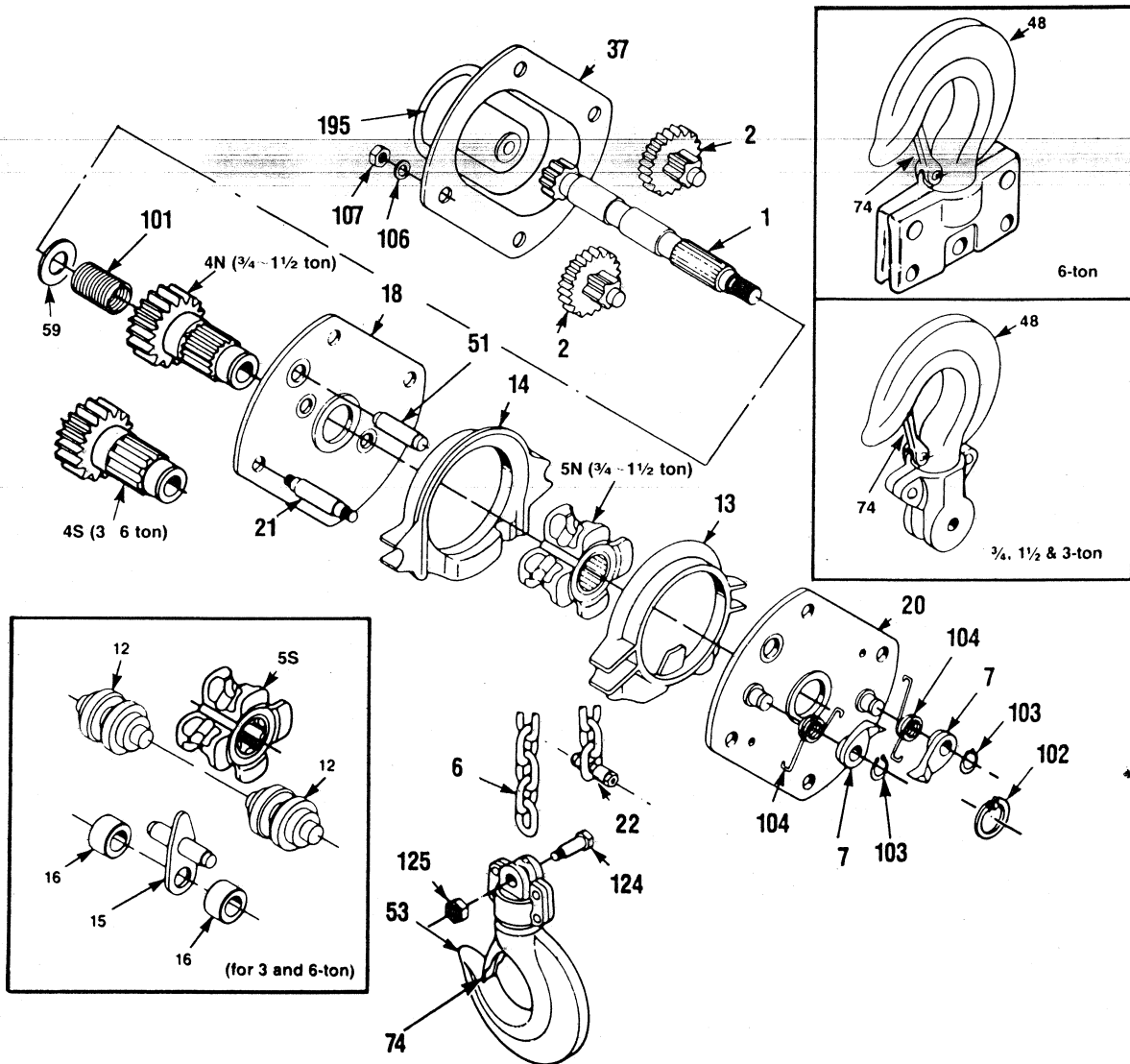

INDEX NO.	PART NAME	QTY. REQ.
1	Pinion Shaft	1
2	Pinion	2
4N	Load Gear (3/4 — 1 1/2 ton)	1
4S	Load Gear (3 — 6 ton)	1
5N	Load Sheave (3/4 — 1 1/2 ton)	1
5S	Load Sheave (3 — 6 ton)	1
6	Load Chain	1 set
7	Pawl	2
12	Load Chain Guide	2
13	Load Chain Guide (A)	1
14	Load Chain Guide (B)	1
15	Stripper	1
16	Stripper Collar	2
18	Gear-side Plate	1
20	Handle-side Plate	1
21	Stay Bolt	4
22	Overtravel Restraint	1

INDEX NO.	PART NAME	QTY. REQ.
37	Gear Cover	1
48	Top Hook Assembly	1 set
51	Yoke Pin	1
53	Bottom Hook Assembly	1 set
59	Washer for Disc Nut (3 ton)	1
74	Hook Latch	1
101	Spring for Shaft	1
102	Snap Ring	1
103	Snap Ring	2
104	Pawl Spring	2
106	Spring Washer	8
107	Hexagon Nut	8
124	Chain Fastening Bolt	1
125	Lock Nut	1
195	Warning Label	1

7-2. Exploded View

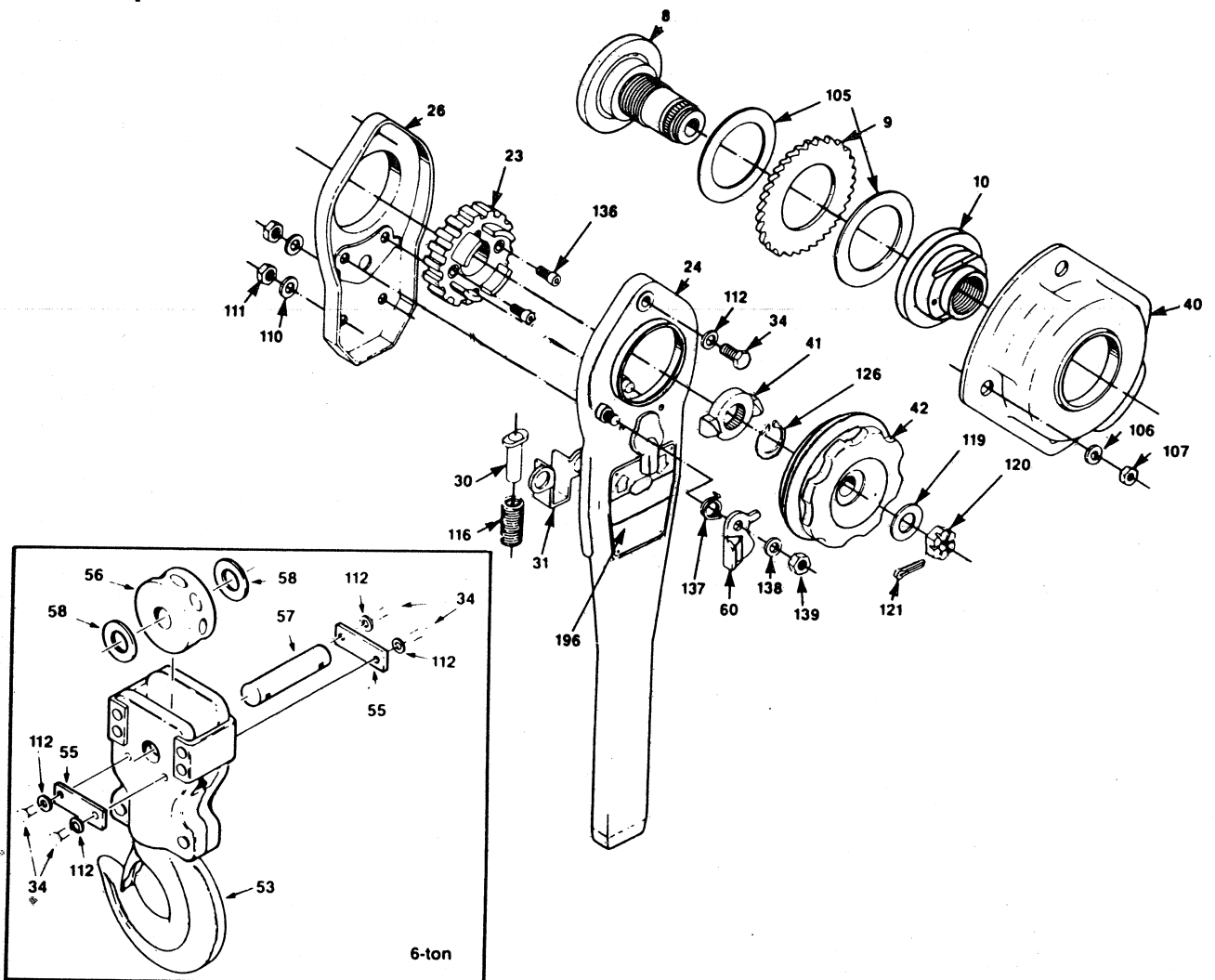

INDEX NO.	PART NAME	QTY. REQ.
8	Disc Hub	1
9	Ratchet Wheel	1
10	Disc Nut Washer	1
23	Disc Nut	1
24	Operating Handle	1
26	Handle Cover	1
30	Spring Shaft	1
31	Shaft Base	1
34	Bolt	1
40	Ratchet Cover	1
41	Check Washer	1
42	Free-chain Knob	1
55	Retainer Plate	2
56	Sheave	1
57	Pin	1
58	Washer	2
60	Free-chain Lever	1

INDEX NO.	PART NAME	QTY. REQ.
105	Friction Discs	2
106	Spring Washer	8
107	Hexagon Nut	8
110	Spring Washer	2
111	Hexagon Nut	2
112	Spring Washer	1
116	Change-over Spring	1
119	Flat Washer	1
120	Check Nut	1
121	Split Pin	1
126	Snap Ring	1
136	Bolts For Disc Nut	2
137	Free-chain Lever Spring	1
138	Flat Washer	1
139	Hex. Lock Nut	1
196	Nameplate	1

DO'S AND DO NOT'S

Manually Lever Operated Chain Hoists

The following warnings and operating practices are intended to avoid unsafe hoisting practices which might lead to personal injury or property damage.

These recommendations apply to all manually lever operated chain hoists used for lifting, pulling, and tensioning type applications.

WARNING: TO AVOID INJURY

1. **DO** read the Hoist Manufacturer's Operating and Maintenance Instructions.
2. **DO** be familiar with hoist operating controls, procedures, and warnings.
3. **DO** make sure that the unit is securely attached to a suitable support before applying load.
4. **DO** maintain firm footing or be otherwise secured when operating unit.
5. **DO** make sure that load slings or other approved sling attachments are properly sized and seated in the hook saddle.
6. **DO** make sure the hook latches, if used, are closed and not supporting any part of the load.
7. **DO** make sure that load is free to move and will clear all obstructions.
8. **DO** take up slack carefully, check load balance, move the load a few inches, and check load holding action before continuing.
9. **DO** make sure all persons stay clear of the supported load.
10. **DO** avoid swinging of load or load hook.
11. **DO** protect load chain from weld spatter or other damaging contaminants.
12. **DO** avoid lever "fly-back" by keeping a firm grip on the lever until operating stroke is completed and the lever is at rest.
13. **DO** promptly report any malfunction, unusual performance, or damage of the unit.
14. **DO** inspect unit regularly, replace damaged or worn parts, and keep appropriate records of maintenance.
15. **DO** use the Hoist Manufacturer's recommended parts when repairing unit.
16. **DO** use hook latches wherever possible.
17. **DO** apply lubricant to load chain as recommended by the Hoist Manufacturer.
18. **DO NOT** lift or pull more than rated load.
19. **DO NOT** use the hoist load limiting device to measure the load.
20. **DO NOT** use damaged unit or unit that is not working correctly.
21. **DO NOT** use unit with twisted, kinked, damaged or worn chain.
22. **DO NOT** apply a load unless chain is properly seated in chain wheel(s) or sprocket(s).
23. **DO NOT** use load chain as a sling or wrap chain around a load.
24. **DO NOT** apply a load if any binding prevents equal loading on all load supporting chains.
25. **DO NOT** apply the load to the tip of the hook.
26. **DO NOT** operate unit when it is restricted from adjusting itself to form a straight line with the direction of loading.
27. **DO NOT** operate except with hand power.
28. **DO NOT** permit more than one operator to pull on lever at the same time.
29. **DO NOT** operate with any lever extension (cheater bar).
30. **DO NOT** allow your attention to be diverted from operating the unit.
31. **DO NOT** operate unit beyond limits of load chain travel.
32. **DO NOT** attempt to "free chain" unit with any load applied.
33. **DO NOT** use hoist to lift, support or transport people.
34. **DO NOT** lift loads over people.
35. **DO NOT** leave a load supported by the unit unattended unless specific precautions have been taken.
36. **DO NOT** allow unit to be subjected to sharp contact with other units, structures or objects through misuse.
37. **DO NOT** allow the chain or hook to be used as a ground for welding.
38. **DO NOT** allow the chain or hook to be touched by a live welding electrode.
39. **DO NOT** remove or obscure the warnings on the unit.
40. **DO NOT** adjust or repair a unit unless qualified to perform such maintenance.
41. **DO NOT** attempt to lengthen the load chain or repair damaged load chain.

Reprinted with the permission of the Hoist Manufacturer's Institute.

**AVAILABLE FROM YOUR LOCAL
YALE® HOIST DISTRIBUTOR:**



Yale Hoists
Highway 1 North
P.O. Box 1000
Forrest City, Arkansas 72335
Phone 1-800-999-6318
FAX 1-800-766-0223