

TEW SERIES
Electric Wire Rope Hoist

3496

Parts, Instructions and Operation
Manual

Yale

Fill in the information below before installing the hoist.

Hoist Model No. _____
Trolley Model No. _____
Voltage _____
Capacity _____
Date of Purchase _____

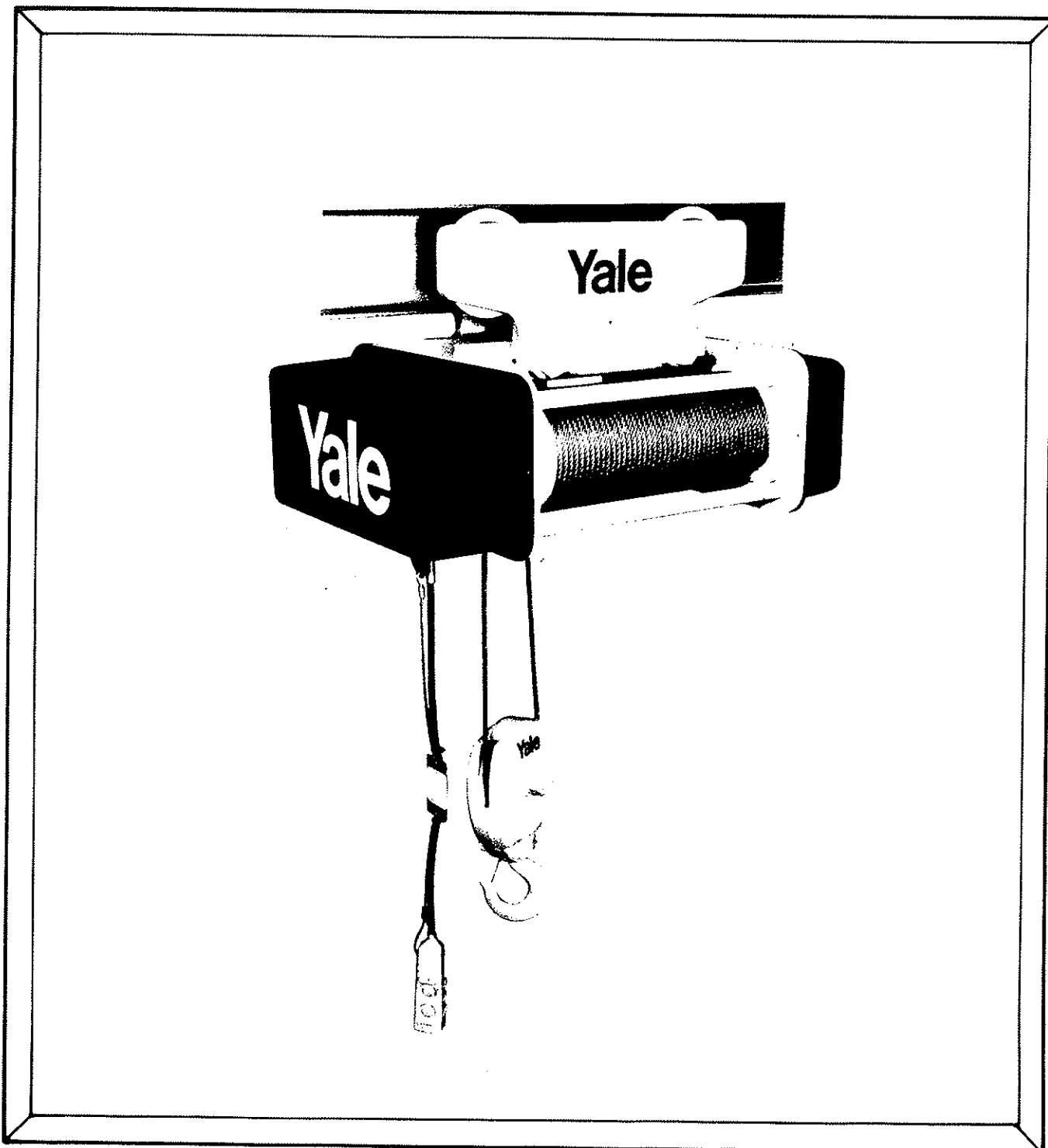

COMMON MODEL NUMBER CODE FOR POWERED HOISTS

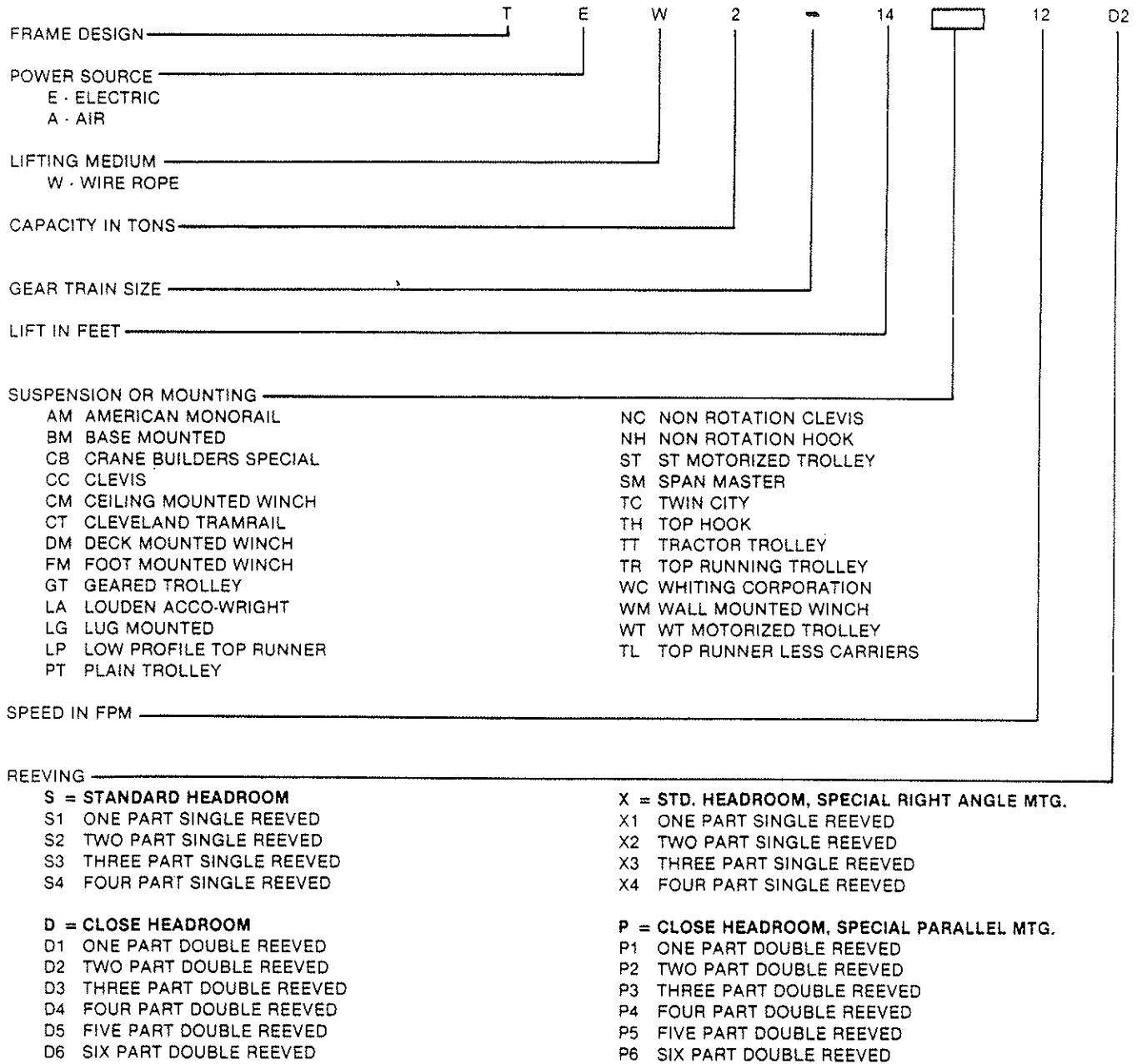

When Replacement Parts Are Needed, Order Only Yale® Factory Engineered Parts

SECTION A

SAFE HOISTING PRACTICES

For your own safety and that of your fellow workers, Material Handling Equipment must be used as recommended by the manufacturer. Failure to heed the following recommendations could endanger your life. Use good common sense and judgment at all times. Safety is the responsibility of the operator of the equipment. You must be competent and attempt to foresee and avoid all hazardous conditions. To be safe as possible, the hoist must be given proper preventive maintenance and testing as described in the **ANSI B30.16** Safety Code for Overhead Hoists and this manual.

BEFORE OPERATING HOIST-OPERATOR MUST READ THIS MANUAL;

1. Do not operate hoist unless you are properly trained, physically fit, and authorized to do so. You must be familiar with all operating controls of the hoist, warnings and instructions on the hoist, the safe hoisting practices listed in this manual, **ANSI B30.16** Safety Code for Overhead Hoists, and all pertinent Federal, State, and Local regulations before beginning operating.
2. Do not allow unqualified personnel to operate the hoist.
3. Test all controls and limit switches and make sure hoist is well lubricated at beginning of each shift. Make sure needed lubrication, adjustments or repairs are made by appointed personnel before operations are begun.
4. Be familiar with the equipment and its proper care. Do not operate hoist if adjustments or repairs are necessary, if any damage or undue wear is known or suspected, or if any warning, operating, or capacity instructions normally attached to hoist are damaged, obscured or missing. Report these items promptly to the proper person and also notify next operator when changing shifts.
5. Do not operate hoist if it is functioning improperly.
6. Do not operate hoist with an out - of - order sign attached until sign has been removed by a properly authorized person.
7. Do not adjust or repair hoist unless qualified for maintenance of hoist.
8. Be sure the power supply is disconnected before maintenance and repair procedure is performed.
9. Do not use the wire rope as a ground for welding.
10. Do not touch a welding electrode to the wire rope.

APPLYING THE LOAD

11. Never wrap the wire rope around the load, or allow it to drag under load.
12. Always use slings or other approved devices to attach load.
13. Be sure the sling is properly seated in the saddle of the hook. Do not allow hook latch to support any part of load.

When Replacement Parts Are Needed, Order Only Yale® Factory Engineered Parts

APPLYING LOAD (Continued)

14. Do not apply a load to tip of hook, or in such a way as to cause bending or prying forces on the hook or hook support block.
15. Be sure wire ropes are not kinked or twisted or that multiple part ropes are not twisted about each other.
16. Do not operate hoist if wire rope is not seated properly in the grooves of the drum or sheaves.
17. Do not load hoist with less than two wraps of rope on the drum, unless a lower limit device is provided, in which case, no less than one wrap shall remain on drum.
18. Center hoist unit over the load before lifting. Avoid side pull.
19. Never pick up a load beyond the rated capacity appearing on the hoist, except for properly authorized tests.
20. Do not use a load limiting device to measure the maximum load to be lifted. It is a safety device only.

MOVING THE LOAD

21. Do not engage in any activity which will divert your attention while operating hoist.
22. Respond to signals from designated personnel only, except for stop signals.
23. Never lift a load with the hoist until you and all other personnel are clear of load.
24. Never carry personnel on the hook or the load.
25. Inch the hoist slowly into engagement with a load, but avoid excessive plugging, in-ching, and quick reversals of load.
26. Do not lift load more than a few inches until it is well balanced in the sling or lifting device.
27. Each time a load approaching rated capacity is handled, check load brake action by raising load just clear of supports and continuing only after you are sure brake is operating properly.
28. Do not transport load over personnel.
29. Make sure load has proper clearance before moving.
30. Avoid swinging of load or load hook when traveling the hoist.
31. On trolley mounted hoists, avoid sharp contact between trolleys or between trolleys and rail stops.
32. Do not use limit devices as a normal means of stopping the hoist. These are emergency devices only.
33. Do not exceed the maximum duty cycle specified by the manufacturer.

When Replacement Parts Are Needed, Order Only Yale® Factory Engineered Parts

SECTION A

PARKING

34. Do not leave load suspended in the air for extended or unattended periods.
35. Keep load block above head level when not in use.

SAFETY LAWS FOR PASSENGER ELEVATORS



CAUTION

DO NOT USE YALE HOISTS OR TROLLEYS FOR PASSENGER ELEVATOR APPLICATIONS.

The safety laws for passenger elevators specify construction details that are not incorporated in Yale Industrial Hoists. We recommend that passenger elevator operation equipment be used that meets all state and national safety codes. Yale Industrial Products, Inc. will not accept responsibility for applications of Yale Hoists on passenger elevators.

INSPECTION, PREVENTIVE MAINTENANCE AND TESTING

A preventive maintenance program should be initiated for this hoist immediately after it is entered into service. The preventive maintenance program should comply with recommendations in the applicable Yale Parts and Instruction Manual, and all pertinent National, Federal, State and local regulations. Regular inspections, maintenance, and testing required should be followed for the life of the hoist and written inspection records kept as specified. Sample inspection check lists are included at back of this manual. Extra inspection check lists can be obtained from your nearest authorized Yale Distributor.

When Replacement Parts Are Needed, Order Only Yale® Factory Engineered Parts

REPAIR PARTS ORDERING INFORMATION

This parts and instruction manual contains information required to install and maintain your Yale TEW Series Hoist. To insure prompt service, each repair parts order should be placed with your local distributor, and must contain the following information:

Please give all information listed below in items (a) thru (e). This will enable your distributor to fill your order promptly.

- (a) Give complete data from hoist nameplate, including hoist serial number, model number, voltage, frequency, and hertz.
- (b) Give part numbers, description and quantity of parts required.
- (c) Give correct shipping destination.
- (d) For ordering motor repair parts, give all data on the hoist and motor nameplates.
- (e) If hoist has been purchased for a special application or environment (such as plating, spark resistant, special hook, special controls, etc.), some of the standard parts listed in this manual may not apply and some special parts may not be shown. In such cases you should contact the factory or your nearest Yale authorized repair station for assistance in ordering parts. A full description of the special application or environment for which the hoist has been adapted will be required.

HOIST SERIAL NUMBERS

The hoist serial number is stamped in the nameplate. Trolley serial numbers are stamped on the trolley sideplate. The nameplates also designate the model number, capacity, speed, current characteristics, and service rating of the hoist or trolley.

RETURN OF PARTS

If it becomes necessary to return the complete hoist or certain parts to the factory, a letter requesting such a return is necessary. This letter should contain an explanation for requesting the return. A return authorization will be issued giving you clearance for returning the hoist or parts to the factory.

When Replacement Parts Are Needed, Order Only Yale® Factory Engineered Parts

SECTION B

INSTALLATION INSTRUCTIONS

Before the unit is shipped from the factory it is rigidly tested and carefully adjusted for proper operation. However, the following points must be checked to insure correct installation and avoid damage to the hoist.

Suspension - Suspend the hoist following the installation procedures for the type of suspension used on your hoist. See pages 8.

Rope And Drum - Check the hoist rope for any signs of damage and make sure it lies properly in the grooves of the drum and sheaves. Make sure the rope is well lubricated. (See chart on page 13.)



CAUTION BEFORE OPERATING THE HOIST, REMOVE THE WOODEN SHIPPING WEDGE

Current Supply - Make sure the electric current supply corresponds with the rating listed on the hoist nameplate. Make sure duty cycle capabilities of hoist are fully understood by all operators.

Electrical Connections - Open the control box and check all the electrical connections to be sure they are tight and that none of the hardware vibrated loose during shipment.

Connect the **power lines** to the point on the reversing switch indicated by the tag and remove tag. If current collectors are used, be sure they make good contact with the conductor bars.



CAUTION

THE HOIST MUST BE GROUNDED. TO DO THIS, CONNECT ONE END OF THE GREEN WIRE IN THE POWER CORD TO A SOLID GROUND AND THE OTHER END TO THE SPECIFIED GROUNDING LUG PROVIDED ON THE HOIST.

Push Button Control



CAUTION

ON POLY PHASE AC HOISTS, IT IS IMPOSSIBLE TO KNOW HOW TO CONNECT THE POWER LINE FOR CORRECT DIRECTION OF THE HOOK TRAVEL.

TO INSURE CORRECT OPERATION OF THE SAFETY LIMIT STOPS IT IS VERY IMPORTANT THAT THE HOOK TRAVEL IS IN THE HOISTING DIRECTION WHEN THE UP BUTTON IS PRESSED. IF IT IS NOT, INTERCHANGE TWO OF THE LINE WIRES FOR 3 PHASE OR TWO OF THE LINE WIRES OF ANY ONE PHASE FOR 2 PHASE OPERATION. IF THE HOIST IS OPERATED WITH INCORRECT POWER CONNECTIONS THE SAFETY LIMIT STOPS WILL BE INEFFECTIVE AND SERIOUS HOIST DAMAGE AND DANGEROUS ACCIDENTS MAY RESULT.



CAUTION

DO NOT ATTEMPT TO REWIRE THE PUSH BUTTON.

When Replacement Parts Are Needed, Order Only Yale® Factory Engineered Parts

Adjustment Of Limit Switches

1. UPPER AND LOWER LIMIT SWITCH.



WARNING EACH STEP OUTLINED BELOW MUST BE FOLLOWED FOR PROTECTION AGAINST ELECTRICAL SHOCK AND INJURY FROM MOVING COMPONENTS.

To adjust the traveling nut limit switches, or to set them at other levels:

- (a) Remove all electrical power from the hoist.
- (b) Remove control cover.
- (c) Adjustment **cams** rotate in a clockwise direction when hoist is lifting and in a counter-clockwise direction when lowering.
- (d) For upper limit switch, move the adjusting disc.
- (e) For lower limit switch, move the adjusting disc.
- (f) Each **cam** includes two movable sectors independent from each other (one red and one grey).
- (g) Move each of the two red and grey discs in the desired direction keeping a gap of $\frac{3}{8}$ " between the discs.



WARNING AT LEAST 1 WRAP OF ROPE MUST REMAIN ON THE DRUM IN THE LOWEST POSITION.

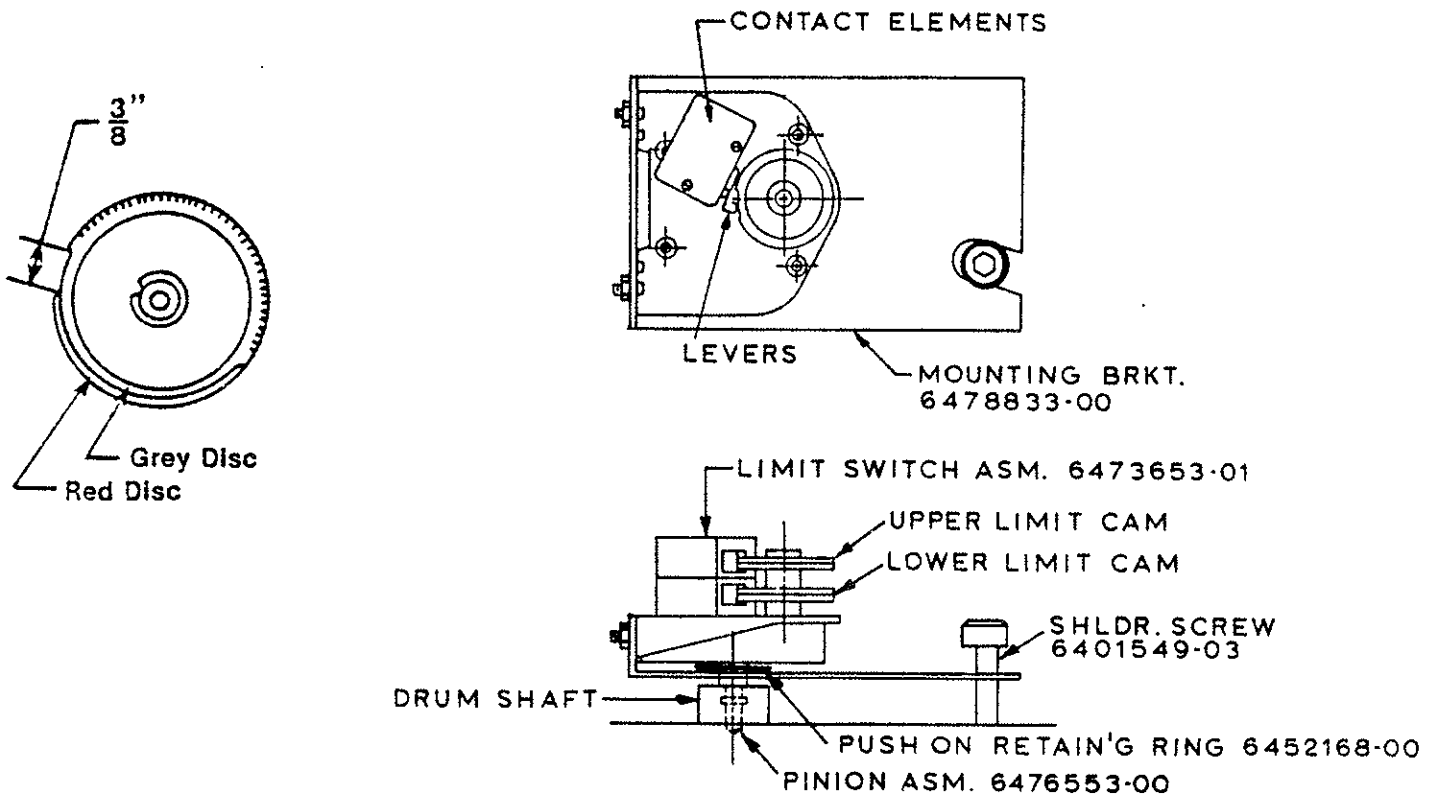

When Replacement Parts Are Needed, Order Only Yale® Factory Engineered Parts

SECTION B

Basic Suspensions - The basic hoist suspension types are ; lug mounted, frame mounted plain trolley, hand chain operated trolley and single beam under running motorized trolley. Before connecting hoist to supporting structure, or mounting on beam or rail, make sure supporting structure has adequate strength to safely support the loading which will be imposed.

When installing lug mounted types, make sure hoist is bolted securely in place with the proper size bolts, that it is level, that nuts on mounting hole bolts are tightened securely, and the lockwashers, or other means of locking the nuts are used.

If hoist is furnished with a motorized trolley, record the serial number in this book for future reference, and refer to the trolley manual included.

To hang hoist furnished with plain, hand chain operated, motorized trolley, first determine the beam size on which the trolley is to be used, then refer to trolley adjustment instructions below for proper spacer arrangements.

Trolley Adjustment - All Yale under running trolleys are properly adjusted at the factory to fit the I-Beam size stated on the order.

NOTE: When disassembling the trolley for installation on the I-Beam, take note of the arrangement of the spacers and washers for correct reassembly.

For installation on I-Beam other than the size preset at the factory, follow the instructions listed below,

Measure the I-Beam flange width and temporarily install the trolley sideplates on the hoist before installation to determine the exact distribution of washers.

The distance between track wheel flanges should be 3/16 inches greater than the beam flange width for straight runway beams, and 3/16 to 1/4 inches on runway systems that include sharp curves. To keep the hoist centered under the I-Beam, the number of washers between the sideplates and the hoist lug should be the same or differ only by one (1) washer. The distribution of washers outside the trolley sideplates is unimportant except that the total number used must be sufficient to keep the nuts engaged.

NOTE: When installing hoist and trolley on beam, tighten nuts snugly so that the trolley sideplates are parallel and vertical.



CAUTION BE SURE THERE IS A LOCKWASHER UNDER EACH NUT.

After the hoist and trolley are installed on the I-Beam, operate the trolley over the entire length of the beam with a capacity load to be sure that adjustment and operation is satisfactory. Then tighten all sideplate nuts to maximum standard torque for bolt size used.

Trolley With Guide Rollers - To adjust trolleys equipped with guide rollers add spacers in even quantities on each side of the spacer block until the distance between guide rollers is 1/8 inches wider than the beam flange width.

NOTE: When properly installed and adjusted the guide rollers should be 1/16 inches from the edge of the I-Beam.

When Replacement Parts Are Needed, Order Only Yale® Factory Engineered Parts

PREVENTIVE MAINTENANCE SCHEDULE

The required periods between inspections will vary due to the wide range of duty cycles and operating conditions encountered with the type of equipment. The following recommended inspection periods are based on duty of specified service rating with single shift operation (40 hours per week) under normal environmental conditions. If the hoist is used under adverse environmental conditions it should be inspected more frequently.

Daily Inspection - Inspect the following items before operating hoist.

- 1 **Manual Controls** - Check all manual controls for proper operation.
- 2 **Electrical Connections** - Check for worn or frayed wires, for loose connections and for damage to, or improper operation of, push button assembly.
- 3 **Limit Switch** - Check the upper and lower limit switch by running the hook **without load**, and at the slowest speed obtainable, to the maximum up and maximum down positions. Then test with increasing speeds up to maximum. The switch should shut the hoist off before the bottom block contacts the rod or weight type limit switch at the upper extreme. 1 Wrap of rope should remain on the drum at the shut-off point at the lowest extreme. If adjustment is necessary, see page 7.
- 4 **Hook** - Check for cracks or deformation. Check for damaged or missing latch. A bent or twisted hook indicates overloading or abuse of unit. Other load bearing components of the hoist or trolley should be inspected if overloading is apparent or suspected. The bottom hook must swivel freely.
5. **Wire Rope** - Check for proper seating in drum grooves. Check for wear, unstranding, fraying, kinks, or broken wires in the wire rope, and condition of end connections. (If damage is noted, see wire rope instructions under monthly inspection.)
6. **Hook Drift** - With a load, the hook should stop promptly when the push button is released. Hook drift of more than 2 inches indicates that the hoist brake is malfunctioning. (See monthly and annual inspection instructions for more details.)
7. **Unusual Conditions** - Excessive noise, lubrication leaks, etc. should be investigated.



CAUTION: DO NOT OPERATE THE HOIST IF ABOVE INSPECTION INDICATES THAT MAINTENANCE IS NEEDED.

Monthly Inspection

1. ALL ITEMS UNDER DAILY INSPECTION.

When Replacement Parts Are Needed, Order Only Yale® Factory Engineered Parts

SECTION B

Monthly Inspection (Continued)

2. **Hook** - Check hook retaining nuts and collars, and means used to secure them. Replace hook if throat opening is in excess of maximum shown in table on page 12, or if there is 10 degrees or more twist from normal plane of hook.
3. **Brake** - Check the function of the brake by lifting a light load (approximately 25% of rated load) 6 to 12 inches above the floor.
4. **Contactors** - Check for burned or badly pitted contacts.
5. **Push Button** - Check the ground connections to be sure that the wire cores from the push button cable and the power cord are secured. Tighten the grounding screw and replace the lockwasher if it is missing. On two button station, replace push button pendant when diaphragm buttons become cracked.
6. **Bearings** - Check all bearings for noisy operation, which is an indication of wear.
7. **Hardware** - Check for loose bolts, nuts and rivets.
8. **Wire Rope** - Check condition of wire rope using inspection check list. (See instructions page 14.) Lubricate per chart on page 13 as needed.



WARNING NEVER ALLOW WIRE ROPE TO OPERATE DRY.

9. **Warning Labels** - Check for absence or illegibility of warning decals and tags and replace if necessary.
10. **Supporting Structure Or Trolley** - If used, should be checked for continued ability to support the imposed loads. Check for loose suspension or support bolts, axle nuts, etc.
11. **Inspection Check List** - Fill out inspection check list at the back of this manual, sign, date and file for future reference.

Quarterly Inspection

1. ALL ITEMS UNDER DAILY AND MONTHLY INSPECTIONS.
2. **Gearing** - Remove gearbox cover and visually inspect gearing for excessive or uneven wear of the gear teeth. Replace if necessary.
3. **Brake** - Check for excessive or uneven disc wear. Clean solenoid plunger seat and check for uneven seating between the plunger and coil.

When Replacement Parts Are Needed, Order Only Yale® Factory Engineered Parts

SECTION B
Annual Inspection

1. ALL ITEMS UNDER DAILY, MONTHLY AND QUARTERLY INSPECTIONS.
2. **Hooks** - Magnetic particle or other suitable crack detecting inspection should be performed if need is indicated by external appearance. Check for loose retaining nuts and collars.
3. **Load Bearing Parts** - Check for worn, cracked or distorted parts, such as suspension housings, outriggers, clevises, yokes, hook blocks, suspension bolts, shafts, locking devices and bearings on hoist, (also on trolley, if so equipped).

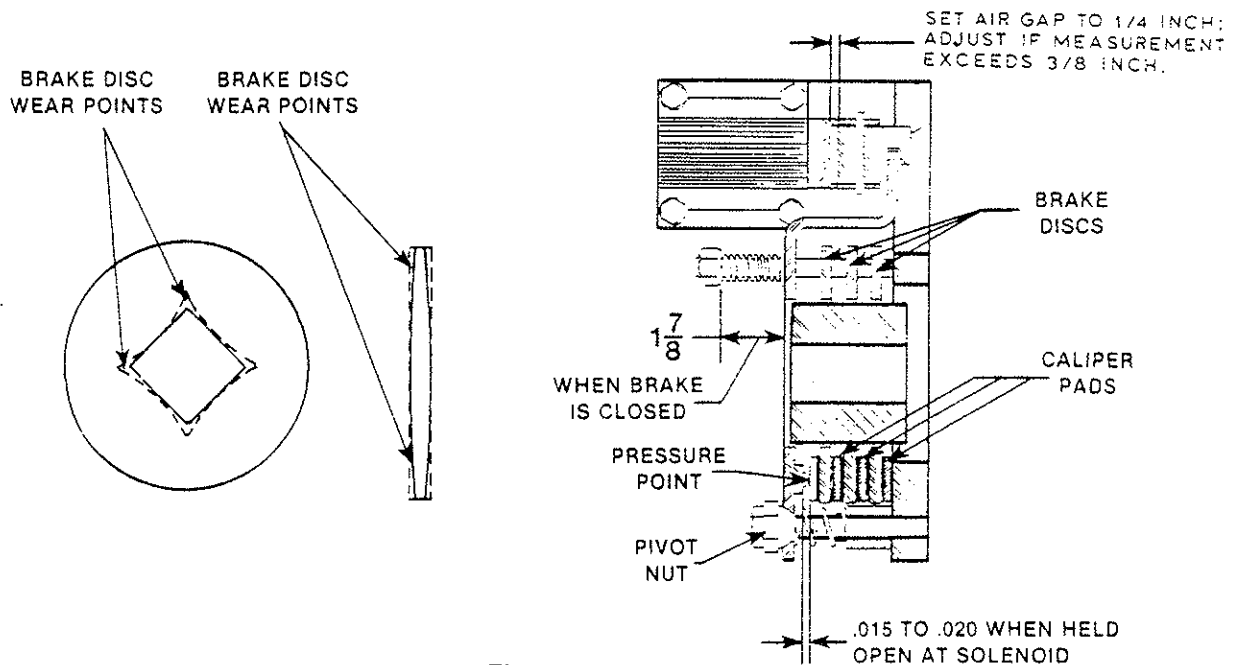

Figure 3

4. **Hoist Brake** - Check for excessive or uneven wear of the discs and caliper pads, and excessive play between the square hole in the discs and the drive block. Clean the solenoid plunger seat and check for uneven seating between the plunger and the coil. Manually hold the brake open and check adjustment as shown in Fig. 3.



CAUTION

PRIOR TO TESTING, ALL SUPPORTING STRUCTURES, ANCHORAGES, AND/OR SUSPENSIONS MUST BE APPROVED BY THE APPOINTED PERSON FOR THE TEST LOADS USED

When Replacement Parts Are Needed, Order Only Yale® Factory Engineered Parts

SECTION B

Annual Inspection (Cont'd.)

5. **Wiring And Terminals** - See that all connections are tight. Terminals are to be securely crimped to wires and the insulation sound. Bent terminals can usually be straightened to provide a tight fit. Replace terminals or wire if necessary.
6. **Sheaves And Drums** - Inspect rope sheaves and drums for excessive wear. When the groove of a sheave or rope drum becomes worn excessively it should be replaced. Worn grooves on the drum or sheave can greatly reduce the useful life of the hoisting rope.
7. **Bearing Lubrication** - The motor, sheave and outer drum bearings are packed with grease at the factory and normally will not need to be lubricated. If conditions require, repack with grease as needed.
8. **Inspection Check List** - Fill out inspection check list at the back of this manual, sign, date and file for future reference.

FUNCTION TESTING AFTER REPAIR

After repair or replacement of parts, function test hoist by operating unloaded hoist into both upper and lower limits, first with slowest speed possible, then with increasing speeds up to maximum. Limit switch mechanisms must be adjusted so they will trip in sufficient time to prevent damage to any part of the hoisting arrangement. See instructions for adjustment of limit switches on page 7. Then test operation of hoist and brake by lifting 100% of rated load. (A normal load lifted may be substituted if no load bearing parts were altered.) A written report of the test should be prepared by the person responsible and kept on file for future reference.

 **CAUTION** PRIOR TO TESTING ALL SUPPORTING STRUCTURES, ANCHORAGES, AND/OR SUSPENSIONS MUST BE APPROVED BY THE APPOINTED PERSON FOR THE TEST LOADS USED.

HOOK DIMENSIONS

CAPACITY IN TONS	E (in.) NORMAL	E (in.) MAXIMUM
1/2	1 1/32	1 7/32
1	1 9/64	1 11/32
1 1/2	1 21/64	1 9/16
2	1 21/64	1 9/16
3	1 15/16	2 1/4
5	1 15/16	2 1/4
6	1 15/16	2 1/4
7 1/2	1 15/16	2 1/4
8	3 1/16	3 9/16
10	3 1/16	3 9/16



WARNING

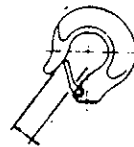

E OPENING WITH LATCH

IF "E" EXCEEDS
MAXIMUM SHOWN
IN TABLE, REPLACE
HOOK AND CHECK OTHER
LOAD BEARING PARTS

When Replacement Parts Are Needed, Order Only Yale® Factory Engineered Parts

**LUBRICATION
EW SERIES HOISTS**

PART	LUBRICANT	LUBRICATION POINT	LUBRICATION INSTRUCTIONS	DRAIN POINT
Gear-case	Moly Cote Grease	Pinion & Gear Teeth		
Wire Rope	Keystone WRD-OW Spray Type Wire Rope Dressing, Or Other Prepared Cable Lubricant	Wire Rope	Light Coat Of Lubricant	

PLAIN AND HAND CHAIN OPERATED TROLLEYS

ALEMITE FITTINGS Ball Valve Oil Holes	GULF XXX No. 1 Grease Or Equal Light Machine Oil
---	---

ST, WT, RT, & TR SERIES TROLLEYS

PART	LUBRICANT	LUBRICATION POINT	LUBRICATION INSTRUCTIONS	DRAIN POINT
Gear-Case	Gulf Crown EP # 2 Grease Or Equal For ST. Use 140 EP Gear Oil For WT And TR	Socket Head Plug In side of Gearcase	Fill Until Lubricant Is Level With Hole	Socket Head Plug In Bottom Of Gearcase
Track Wheel Pinion & Gear Teeth	Moly Cote Grease	Pinion & Gear Teeth	Depending On Applications Light Coating Of Grease	

TT SERIES TROLLEYS

PART	LUBRICANT	LUBRICATION POINT	LUBRICATION INSTRUCTIONS	DRAIN POINT
Gear-case & Chain Case	Gulf Crown EP # 2 Grease Or Equal	Socket Head Plug On Side Of Chain Case	Fill Until Grease Is Level With Hole	Socket Head Plug In Bottom Of Gearcase

When Replacement Parts Are Needed, Order Only Yale® Factory Engineered Parts

SECTION B

WIRE ROPE INSPECTION

All wire rope should be inspected once a month and a signed and dated inspection report maintained. The Inspection Check Lists at back of this manual can be used to record these inspections. Wire rope should be replaced if any of the following conditions are noted.

1. Twelve randomly distributed broken wires in one rope lay, or four broken wires in one strand in one rope lay.
2. Wear of one-third (1/3) of the original diameter of outside individual wires.
3. Kinking, crushing, bridging or any distortion of the wire rope structure.
4. Evidence of heat damage.



"Broken Wires"



"Kinked"





Bird Cage

5. Reductions from nominal diameter of more than the following values.

New Rope Diameter	Maximum Reduction
5/16 Inch and under	1/64 Inch
3/8 Inch Thru 1/2 Inch	1/32 Inch
9/16 Inch Thru 3/4 Inch	3/64 Inch
7/8 Inch Thru 1 1/8 Inch	1/16 Inch

6. Rope sockets should be inspected for broken wires. If broken wires are noted, the rope should be replaced.

 **CAUTION** **REPLACEMENT WIRE ROPE SHOULD BE THE SAME SIZE, GRADE AND CONSTRUCTION AS THE ORIGINAL WIRE ROPE. BEFORE REPLACING WIRE ROPE, READ PROCEDURE ON PAGE 19. AFTER WIRE ROPE REPLACEMENT CHECK FOR PROPER LIMIT SWITCH OPERATION. (SEE PAGES 7.)**

 **CAUTION** **ROPE PILE-UP ON THE HOISTING DRUM WILL SEVERLY DAMAGE THE HOISTING ROPE. IF THIS CONDITION IS NOTED THE HOISTING ROPE SHOULD BE INSPECTED ACCORDING TO THE ABOVE PARAGRAPH ON WIRE ROPE INSPECTION. IF DAMAGED ROPE IS FOUND, CHECK DRUM AND FRAME MEMBERS FOR DAMAGE.**

When Replacement Parts Are Needed, Order Only Yale® Factory Engineered Parts

Yale Hoisting Equipment

HOW TO MEASURE WIRE ROPE

The correct diameter of a wire rope is the diameter of a circumscribed circle which will enclose all the strands. It is the largest cross-sectional measurement as illustrated below. The measurement should be made carefully with calipers. The illustrations below show the correct and incorrect method of measuring the diameter of wire rope.

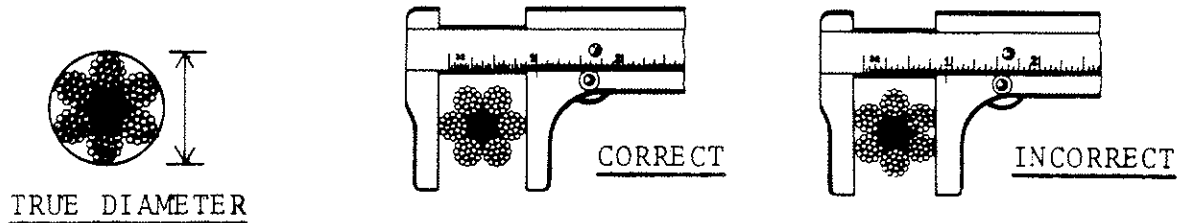

PROCEDURE FOR REEVING WIRE ROPE ON DRUM

**NOTE TRAVELING NUT LIMIT SWITCH MUST BE PRESET BEFORE REEVING, PER INSTRUCTION-
SON PAGES 7 AND 34 AND RE-ADJUSTED PER STEPS (f) THRU (n) AFTER REEVING.**
DOUBLE REEVED UNITS

1. Anchor the rope in the drum on one side. Install rope retainer.
2. Stretch out rope to make sure there are no twists or kinks.
3. Reeve the free end of the rope through the bottom block and all sheaves. (See page 17.)
4. Anchor the free end of the rope in the other side of the drum. Install rope retainer.
5. Push the "UP" button to reeve both sides of the drum, making sure there is enough force on the rope to insure proper reeving in all drum grooves.

NOTE WHEN THE BOTTOM BLOCK IS RAISED TO THE UPPER LIMIT THE BLOCK SHOULD BE AT THE MID-POINT OF THE UNGROOVED PORTION OF THE DRUM AND EVEN WITH THE IDLER SHEAVE. IF THIS IS NOT SO, THE UNIT IS REEVED INCORRECTLY.

When Replacement Parts Are Needed, Order Only Yale® Factory Engineered Parts

SECTION B

SINGLE REEVED UNITS

1. Anchor the rope in the drum. Install rope retainer.
2. Stretch out rope to make sure there are no twists or kinks.
3. Reeve the free end of the rope through the bottom block. (see next page.)
4. Attach the dead end of the rope to the suspension frame.
5. Push the "UP" button to reeve the drum making sure there is enough force on the rope to insure proper reeving in all drum grooves.



CAUTION

ALL UNITS MUST HAVE A MINIMUM OF 1 WRAP OF WIRE ROPE ON THE DRUM WHEN THE BOTTOM BLOCK IS IN THE LOWEST POSITION.

REEVING TYPES

Yale powered wire rope hoists and winches are reeved in various ways to gain desired advantages. Proper reeving insures maximum life of the hoist drum, wire rope and bottom block assembly while obtaining the best characteristics of capacity, lift and speed for the basic unit.

Reeving is either "single" or "double," i.e. one or two ropes coming from the drum. Standard headroom hoists are single reeved; close headroom hoists are double reeved. Part designates the mechanical use of each rope coming from the drum.

The table and drawings pictured on the next page show the characteristics of each principal method of reeving.

The advantages of single reeved units are fewer ropes and longer lifts from comparable units. Advantages of double reeved units include minimum lateral hook drift (keeping load in the same approximate position in relation to the drum and beam) and a lower hoist headroom requirement.

When Replacement Parts Are Needed, Order Only Yale® Factory Engineered Parts

Yale Hoisting Equipment

REEVING TYPES

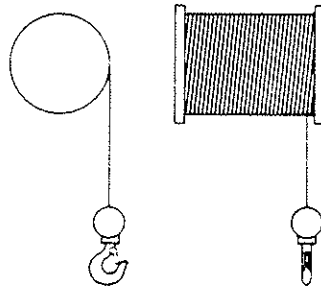

1 part single
S1

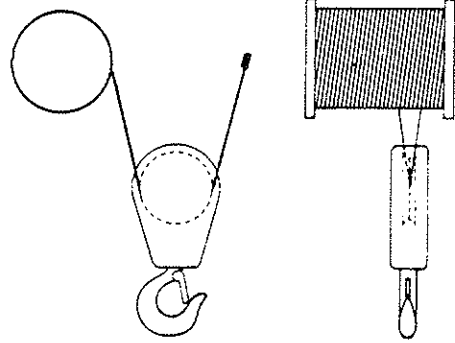

2 part single
S2

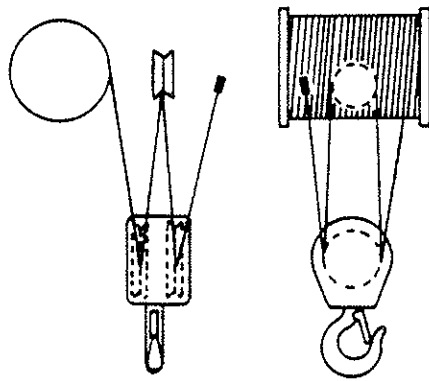

4 part single
S4

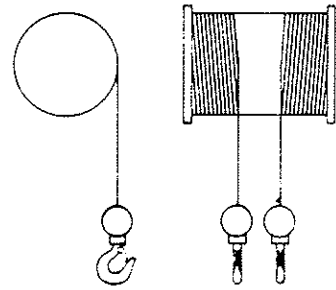

twin rope (1 part double)
D1

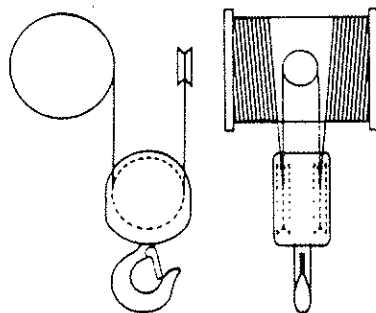

2 part double
D2

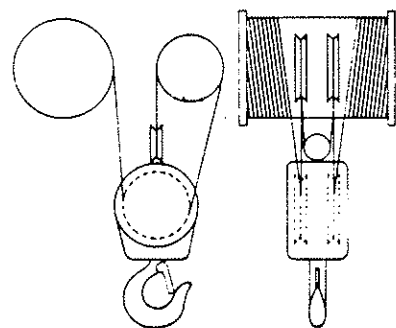

3 part double
D3

When Replacement Parts Are Needed, Order Only Yale® Factory Engineered Parts

This page intentionally left blank

When Replacement Parts Are Needed, Order Only Yale® Factory Engineered Parts

DISASSEMBLY

 **CAUTION:** BEFORE DOING MAINTENANCE WORK ON THIS HOIST, READ THE FOLLOWING INSTRUCTIONS THOROUGHLY. REFER TO THE REPLACEMENT PARTS SECTION FOR PARTS IDENTIFICATION.

To completely disassemble the hoist, follow the disassembly procedures in the order listed.

To disassemble any one specific part of the hoist, follow the instructions for that specific section.

DISASSEMBLY

I. Remove Hoist Rope, Bottom Block Or Bottom Hook

A. Standard Headroom Hoist

1. Remove or re-adjust traveling nut or geared limit to negate lower limit [see instructions (a) thru (f) on page 7.]
2. Operate hoist in down direction until no cable remains on the drum. Remove rope retainers and pull rope sockets from the drum.
3. Remove power from the hoist.
4. Disassemble bottom block and remove hoist rope.
5. Remove pin holding the cable in the hoist frame.

B. Low Headroom Hoist

1. Follow procedures in I.A - 1, 2 and 3.
2. Remove pin holding equalizer sheave yoke in hoist frame.
3. Remove axle holding the sheave in the yoke and remove cable.

II. Remove motor brake



CAUTION

CUT-OFF ALL POWER TO THE HOIST BY DIS-CONNECTING THE POWER FEED LINE BEFORE ATTEMPTING SERVICE OR REPAIR.

When Replacement Parts Are Needed, Order Only Yale® Factory Engineered Parts

SECTION B

DISASSEMBLY (Continued)

1. Disconnect coil wire leads.
2. Remove four socket head screws holding brake to sideplate. Remove brake.
3. Remove retaining ring holding hub to shaft. Remove hub.

III. Remove Gearing

1. Loosen and remove four (4) nuts holding back bearing plate.
2. Remove back plate.
3. Remove snap rings to remove drum gear or motor pinion.

IV. Remove Hoist Motor

1. If possible, run hoist in down direction and clear all rope from the hoist drum.
2. Remove all power from the hoist. Remove motor brake and brake hub as in procedure II.
3. Disconnect motor leads. Disconnect limit switch chain drive.
4. Remove motor pinion and drum gear.
5. Remove bolts holding frame sideplates to suspension channel, motor and frame spacers.
6. Separate the sideplates to allow motor to be removed.

V. Remove Hoist Rope Drum

1. Follow procedures in I, II, III and IV.
2. Separate the sideplates to allow the drum to be removed.

When Replacement Parts Are Needed, Order Only Yale® Factory Engineered Parts

DISASSEMBLY (Continued)

VI. Remove Traveling Nut Limit Switch.

- A. Geared upper and lower limit switch
 - 1. Disconnect all power from hoist.
 - 2. Remove the control cover, disconnect the limit switch wiring. Note the color coding or tag the wires so they can be reconnected correctly.
 - 3. Remove limit switch chain drive.
 - 4. Remove the two screws and lockwashers that hold the limit switch assembly to the sideplate. Remove the limit switch assembly.

VII. Remove Controls

- 1. Remove all power from the hoist.
- 2. Remove control and cover. Disconnect and tag all wires coming into the control area.
- 3. Remove screws holding control panel on sideplate.
- 4. Remove control panel.

REASSEMBLY

The assembly sequence is basically the reverse of the disassembly sequence previously described. The following special instructions should be observed during reassembly:

- 1. Inspect the **drum support bearing** at both ends of the hoist drum. Replace if damaged.
- 2. Be sure the **motor brake** is properly adjusted before it is installed on the gearcase. See Page 11.

When Replacement Parts Are Needed, Order Only Yale® Factory Engineered Parts

SECTION B

TROUBLE SHOOTING

UNIT NOISY

Possible Cause	Remedy
(a) Nicked gears.	(a) Examine teeth for nicks and burrs. Remove with honing stone, replace if teeth are severely damaged.
(b) No grease on gears.	(b) Apply grease to pinion and gear teeth.
(c) Defective bearing.	(c) Replace.

LOAD DRIFTS OR DROPS

Possible Cause	Remedy
(a) Brake slipping.	(e) Adjust brake. Check for oil on brake discs.
(b) Brake not closing.	(f) Adjust for proper clearance. (See Page 11).

When Replacement Parts Are Needed, Order Only Yale® Factory Engineered Parts

TROUBLE SHOOTING (Continued)

BRAKE COIL BURNED OUT



CAUTION ALWAYS DISCONNECT POWER CIRCUIT BEFORE WORKING ON ELECTRICAL COMPONENTS.

Possible Cause	Remedy
(a) Wrong coil.	(a) Replace with proper voltage coil.
(b) Brake too tight.	(b) Adjust brake (See Section J).

HOIST DOES NOT OPERATE

Possible Cause	Remedy
(a) Blown or loose fuse.	(a) Replace or tighten fuse.
(b) Tripped breaker.	(b) Reset breaker.
(c) Loose terminal screws.	(c) Check and tighten all loose screws.
(d) Low voltage.	(d) Check voltage at line side of reversing switch.
(e) Low voltage or no voltage to push button circuit.	(e) Check voltage at output side of transformer. Wrong voltage tap may have been selected. For example: 460 volt tap used when line voltage is 230 volt. Check control circuit fuse.
(f) Defective push button.	(f) Check contact points at push button to see if points touch. If not, replace.
(g) Defective push-button cord. (Wire may be pinched, broken or bare).	(g) Check for continuity of ground.
(h) Burned coil in reversing switch.	(h) Replace.
(i) Reversing switch plunger jammed in switch.	(i) Check for burned coil. Dis-assemble and replace defective components. Do not lubricate.
(j) Burned contact tips.	(j) Replace tips.
(k) Brake coil burned.	(k) Replace, check to make sure coil is proper coil for voltage applied.
(l) Defective stator.	(l) Rewind stator.
(m) Rotor loose on shaft.	(m) Reposition rotor and tack weld in place.

When Replacement Parts Are Needed, Order Only Yale® Factory Engineered Parts

SECTION B

TROUBLE SHOOTING (Continued)

Possible Cause

Remedy

MOTOR OVERHEATS, EXCESSIVE AMPERAGE DRAW

Possible Cause

Remedy

- | | |
|-------------------------------|---|
| (a) Defective stator. | (a) Replace or rewind stator. |
| (b) Worn motor bearings. | (b) Replace. |
| (c) Bent rotor shaft. | (c) Replace rotor shaft. |
| (d) Rotor dragging in stator. | (d) Tighten motor bolts. Check for foreign matter between rotor and stator. Check for worn motor bearings. |
| (e) Stator loose in frame. | (e) Rewind stator if necessary. Reposition and anchor in accordance with motor manufacturer's instructions. |

MOTOR NOISY

Possible Cause

Remedy

- | | |
|-------------------------------|---|
| (a) Motor bolts loose. | (a) Tighten. |
| (b) Rotor dragging in stator. | (b) Check for bent rotor shaft or worn bearings. Replace defective parts. |
| (c) Motor bearings loose. | (c) Replace bearings. |

TRANSFORMER OVERHEATS OR BURNS OUT

Possible Cause

Remedy

- | | |
|-------------------------------------|--|
| (a) Wrong tap used on primary side. | (a) Replace transformer if necessary. Primary tap must match line voltage. |
| (b) Shorted transformer. | (b) Replace. |
| (c) Shorted control circuit. | (c) Correct short. |

When Replacement Parts Are Needed, Order Only Yale® Factory Engineered Parts

TROUBLE SHOOTING (Continued)

REVERSING SWITCH COIL BURNED OUT

Possible Cause	Remedy
(a) Wrong coil used.	(a) Replace coil. Be sure coil conforms to voltage of circuit it is used on.
(b) Jammed plunger.	(b) Disassemble and clean. Do not lubricate plunger or coil.
(c) Shorted coil.	(c) Replace.

HOIST SHOCKS OPERATOR

Possible Cause	Remedy
(a) Power leads or control wires shorted to hoist frame.	(a) Repair or replace.
(b) Grounded motor.	(b) Replace.
(c) Slight electrical leakage from any of the electrical components on hoist.	(c) Make sure hoist is properly grounded.

When Replacement Parts Are Needed, Order Only Yale® Factory Engineered Parts

TEW SERIES

26

AUGUST 1984

REPAIR PARTS

Recommended Spare Parts For 1 Year Operation

Page Number

1. Motor Brake Solenoid. _____	30
2. Contactor Magnetic Coils. _____	31
3. Contactor Parts Kit. _____	31
4. Wire Rope. _____	29
5. Hook Latch Kit. _____	36-38
6. Transformers. _____	31
7. Gasket. _____	29
8. Motor Brake Disc. _____	31

When Replacement Parts Are Needed, Order Only Yale® Factory Engineered Parts

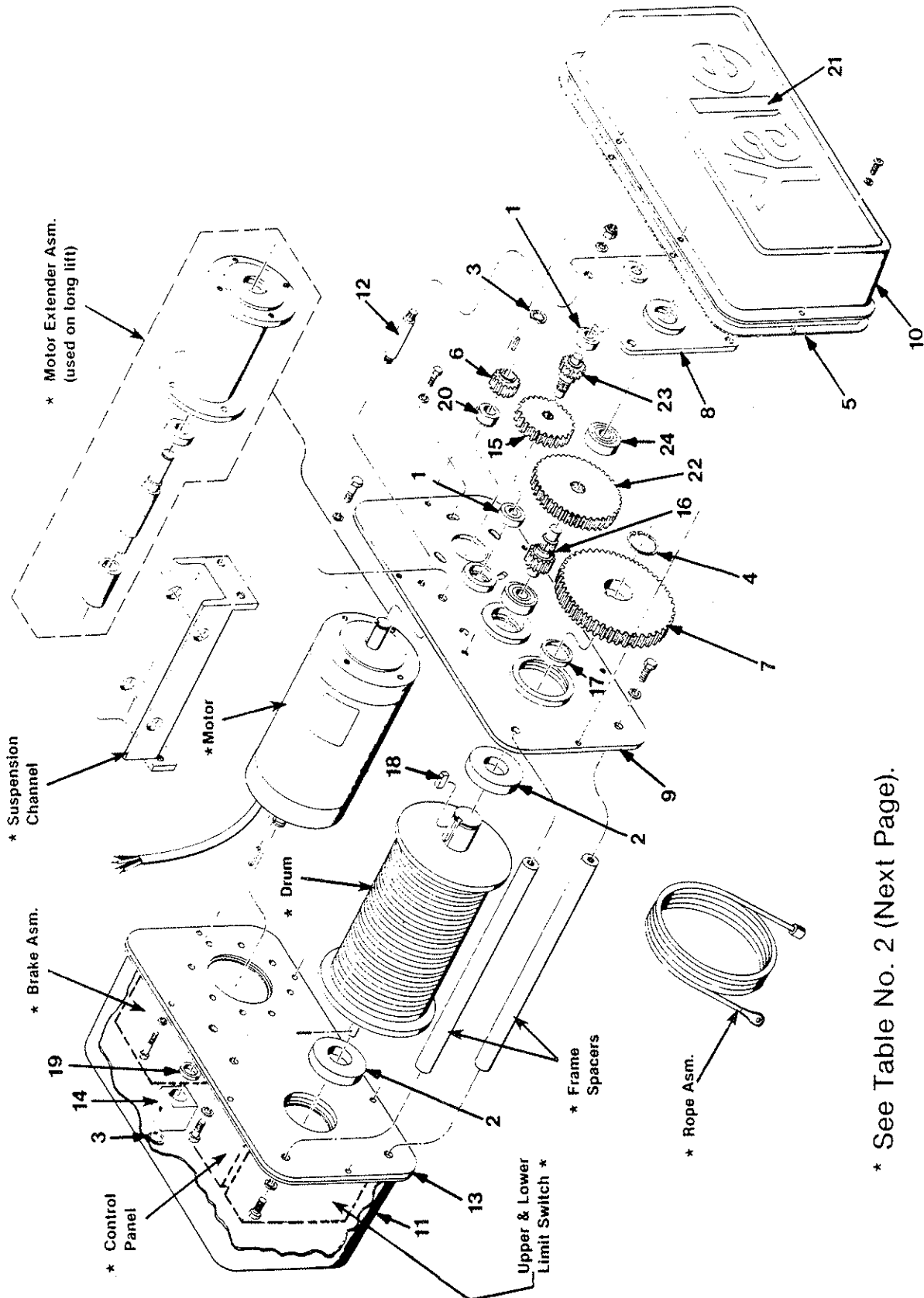

* See Table No. 2 (Next Page).

When Replacement Parts Are Needed, Order Only Yale® Factory Engineered Parts

Yale Hoisting Equipment

REPAIR PARTS

ITEM NUMBER	PART NUMBER	DESCRIPTION	QTY.
1	0100836-00	BRG. BALL	2
2	0151206-00	BRG. BALL	2
3	0159152-00	RET. RING EXT. .042X0.81 5100-37	2
4	6401529-01	RET. RING EXT. .062X1.64 5108-17	1
5	6456373-81	GASKET SELF ADH 1/4X5/8 FT	10
6	6469573-00	MOTOR PINION - 18 TEETH	1
7	6469713-00	DRUM GEAR - 64 TEETH	1
8	6469763-00	GEARCASE, BACK PLATE	1
9	6469773-00	SIDEPLATE, GEAR END	1
10	6469813-01	COVER GEAR END	1
11	6469813-02	COVER, BRAKE END	1
12	6469863-00	STAND-OFF	4
13	6469883-00	SIDEPLATE, BRAKE END	1
14	6469933-01	BLOCK BRAKE DRIVE	1
15*	6481943-00	HIGH SPD GEAR - 42 TEETH	1
16	6469973-00	SLOW SPD PINION - 12 TEETH	1
17	6470023-00	SPACER DRUM GEAR	1
18	6470033-01	KEY DRUM GEAR - .5 SQ X .37	1
19	6470463-01	SPACER DRIVE BLOCK	1
20	6470463-02	SPACER MTR. PINION	1
21	6470673-00	DECAL, (YALE) 5.62X11.68	2
22	SEE TABLE 1	INTERMEDIATE GEAR	1
23	SEE TABLE 1	INTERMEDIATE PINION	1
24	0220557-00	BRG. BALL	2

*REQS. (2) 6481913-00 SPACERS

TABLE 1

**REQS. (2) 6481923-00 SPACERS

RATIO	ITEM 22 **		ITEM 23	
	NO. TEETH	P/N	NO. TEETH	P/N
80.9:1	78	6481933-01	12	6469953-01
49.8:1	72	6481933-02	18	6469953-02
36.3:1	67	6481933-03	23	6469953-03

TABLE 2

MODEL			SUSP.	ROPE	BOTTOM	FRAME	MOTOR	DEAD END	TOP	SHEAVE	PLN	GRD	
CAP.	LIFT	RVG.	CHANNEL	ASSEMBLY	BLOCK	SPACERS	EXTENDES	P/N	SHEAVE(S)	SHAFT	TRO	TRO	
1/2	26	S2	647012301	647015301	646954201	080573900	646985301	N/A	647018301	N/A	N/A	646979202	646979201
1	26	S2	647012301	647015301	646954201	080573900	646985301	N/A	647018301	N/A	N/A	646979202	646979201
1	48	S2	647012302	647015302	646954202	080573900	646985302	647520200	647018301	N/A	N/A	646980202	646980201
1/2	21	S2	647000301	646985301	646956201	646961200	646985301	N/A	647018301	N/A	N/A	646981202	646981201
1/2	40	S2	647000302	646985302	646956202	646961200	646985302	647520200	647018301	N/A	N/A	646982207	646982206
2	24	S4	647024300	647016300	646955202	010155700	646985302	647520200	647018301	010989200	647026300	646982207	646982206
3	20	S4	647024300	646985302	646957202	646970200	646985302	647520200	647018301	010989200	647026300	646982202	646982201
1/2	20	D2	647027300	647016302	646958202	010154900	646985302	647520200	N/A	647905100	647022300	646980202	646980201
1	20	D2	647027300	647016302	646958202	010155900	646985302	647520200	N/A	647905100	647022300	646980202	646980201
1/2	20	S2	647027300	647016302	646958202	646964200	646985302	647520200	N/A	647905100	647022300	646980207	646980206
2	14	D3	647052300	647016302	646959202	646983200	646985302	647520200	N/A	010959200	645203117	646982207	646982206

When Replacement Parts Are Needed, Order Only Yale® Factory Engineered Parts

MOTOR BRAKE

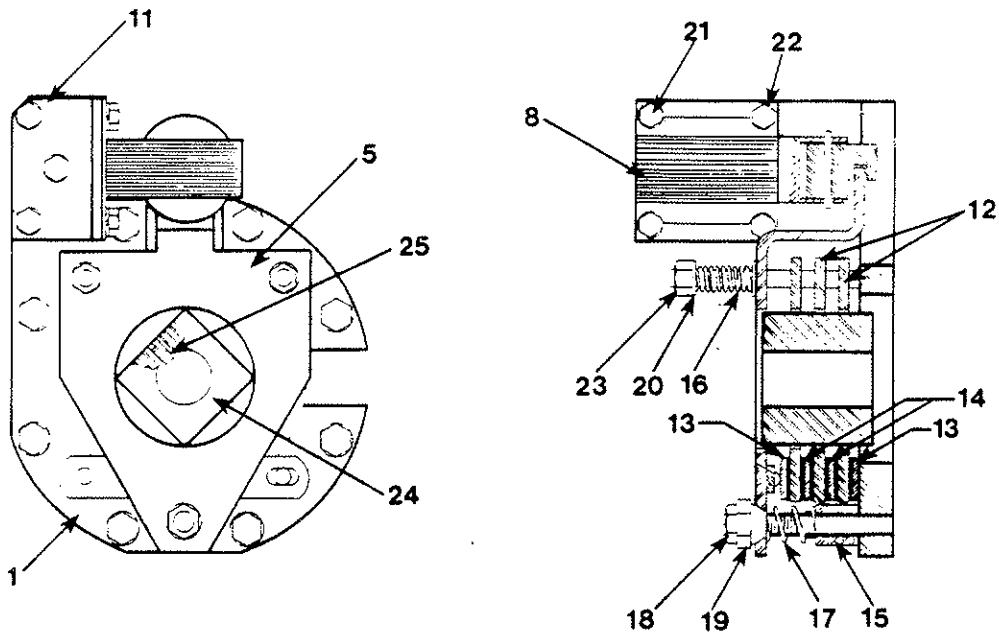

ITEM	PART NUMBER	QTY.	DESCRIPTION
1	646923300	1	BASE PLATE ASM. (Include items 2, 3 & 4)
2		2	GUIDE ROD
3		2	SPRING ROD
4		1	PIVOT POST
5	646921300	1	LEVER
8	647010202	SELECT	SOLENOID 200V.
	647010203	1	SOLENOID 230V.
	647010204		SOLENOID 460V.
	647010205		SOLENOID 575V.
11	646934300	1	SOLENOID BRACKET
12	646860301	3	BRAKE PLATE
13	646847301	2	PLATE ASM. (Single)
14	646847302	2	PLATE ASM. (Double)
15	*	1	PIVOT SPACER
16	*	2	SPRING (Torque)
17	*	1	SPRING (Pivot)
18	*	1	LOCKNUT, STOVER
19	*	1	PIVOT NUT
20	*	3	FLAT WASHER 5/16
21	*	7	HEX HD SCREW 1/4-20X1/2
22	*	7	LOCKWASHER 1/4
23	*	2	LOCKNUT 5/16-24 NYLOK
24	646993301	1	DRIVE BLOCK
25	032009100	1	KEY 3/16X3/16X1 1/4

*Hardware Kit (647011200)

When Replacement Parts Are Needed, Order Only Yale® Factory Engineered Parts

Yale Hoisting Equipment

REPAIR PARTS

TEW PARTS MANUAL

CONTROL SECTION

Control Transformer 25VA

VOLTAGE	PART NUMBER
200 115	643739306
230 115	643739304
460 115	643739304
575 115	643739308
200 24	643739305
230 24	643739302
460 24	643739302
575 24	643739307

REVERSING CONTACTOR	COIL	CONTACT KIT
640155901 24V. COIL	503061800	640002800
640155902 115V. COIL	503062800	640002800

TRANSFORMER NINE DIGIT PART NUMBER STAMPED HERE

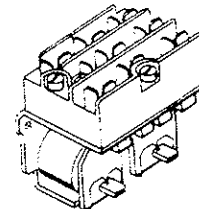
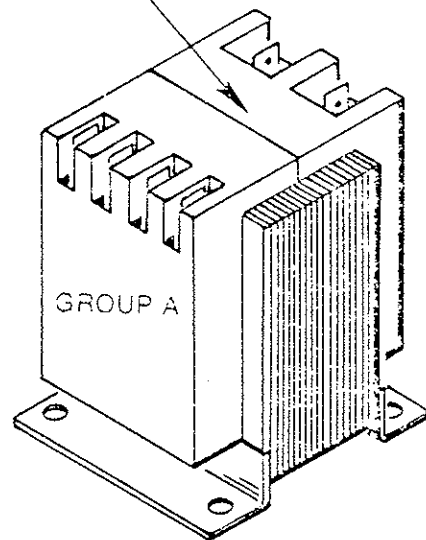

When Replacement Parts Are Needed, Order Only Yale[®] Factory Engineered Parts

SECTION 2710/80

PUSH BUTTON

2740		Enclosure (Less) (Elements)	Two Button Four Button Six Button Eight Button Ten Button	6452753-02 6452753-04 6452753-06 6452753-08 6452753-10
2750		Elements	Single Speed (Pair)	6452763-01
			Two Speed (Pair)	6452763-02
			Five Speed (Pair)	6452763-05
			Maintained/ Momentary	6455953-00
		Selector Switch	Two Position Three Position	6463493-00 6455983-00
		Pilot Light	115 Volt Red	6455973-00
		Potentiometer	1000 Ohm	6451821-01
		Elements	Single Button (One)	6456263-00
		Off/On Element	Locking Non-Locking	6455963-00
	Closing Plate		6452883-00	

When Replacement Parts Are Needed, Order Only Yale® Factory Engineered Parts

Yale Hoisting Equipment

SECTION 2710/80

PUSH BUTTON

2760	Component Number	Markings				
		1	1A	1B	2	3
	6452803-01	Hoist			Up	Down
	6452803-02	Trolley			East	West
	6452803-03	Trolley			Forward	Reverse
	6452803-04	Trolley			North	South
	6452803-05	Bridge			Forward	Reverse
	6452803-06	Bridge			East	West
	6452803-07	Bridge			North	South
	6452803-08				Start	Stop
	6452803-09				Reset	Stop
	6452803-10					
	6452803-11				Forward	Reverse
	6452803-12				North	South
	6452803-13				East	West
	6452803-14				In	Out
	6452803-15				Left	Right
	6452803-16	Crane			Forward	Reverse
	6452803-17				Off	On
	6452803-18				On	Off
	6452803-19				Stop	Start
	6452803-20				Stop	Reset
	6452803-21					Run
	6452803-22				Inch Slow	Fast

2710		Complete Station	Two Button	Up-Down	6480701-01
			S / Speed	Fwd- Rev	6480701-02
			Two Button	Up-Down	6469823-01
			Two Speed	Fwd-Rev	6469823-02
2710		COMPLETE STATION	TWO BUTTON S/SPEED	6471993-00	
2710		For Explosion Proof or other Special Push Buttons, Refer to Computer Parts list in front of Manual.			

When Replacement Parts Are Needed, Order Only Yale® Factory Engineered Parts

THIS PAGE LEFT INTENTIONALLY BLANK

THIS PAGE LEFT INTENTIONALLY BLANK

Bottom Block Assembly - 2 & 3 Ton, 4 Part Single

Assemblies 010155700 - 2 Ton
646970200 - 3 Ton

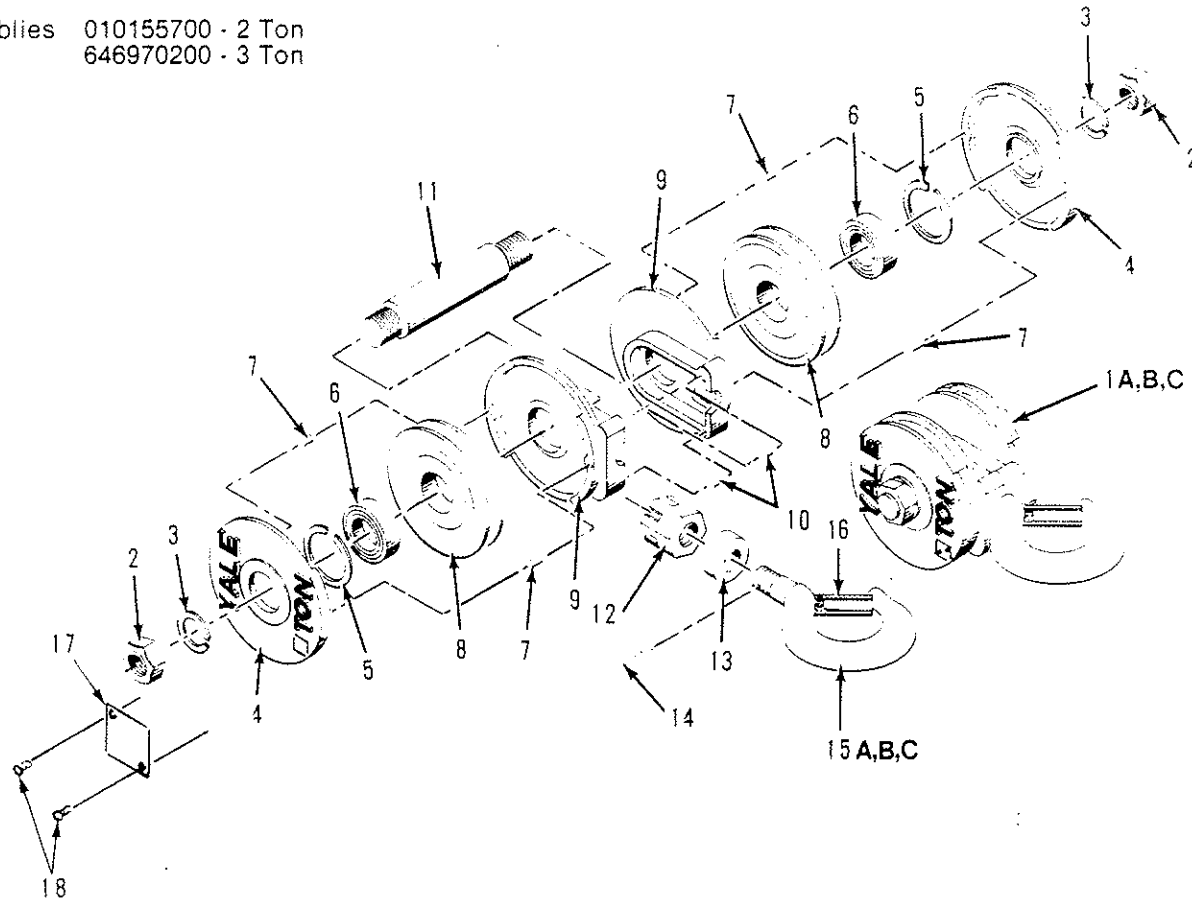

ITEM NUMBER	PART NUMBER 2 TON	PART NUMBER 3 TON	DESCRIPTION	QTY.
1A	0101557-00	6469702-00	BOTTOM BLOCK ASM.(Incl. Items 2 Thru 15A,16,17 & 18)	1
1B	5037160-00		BOTTOM BLOCK ASM.(Incl. Items 2 Thru 14,15B,16,17 & 18)	1
1C	6434652-00		BOTTOM BLOCK ASM.(Incl. Items 2 Thru 14,15C,16,17 & 18)	1
2	0149716-00	0149716-00	NUT	2
3	0150272-00	0150272-00	LOCKWASHER	2
4	0667914-00	6470343-00	BOTTOM BLOCK COVER	2
5	0110016-00	5003439-14	RETAINING RING	2
6	0100210-00	0151281-00	BEARING	2
7	0116526-00		DOWEL PIN	4
8	0109892-00	6470303-00	BOTTOM BLOCK SHEAVE	2
9	0221089-00	6470383-00	CENTER HALF/CENTER WELDMENT	2/1
10	0116531-00		DOWEL PIN	2
11	0109866-00	6470313-00	SHAFT	1
12	0629014-00	6401379-02	SLOTTED NUT	1
13	0220677-00	6465168-00	BEARING	1
14	0230250-00	0655093-00	ROLL PIN	1
*15A	6478990-00	6479070-00	LOWER HOOK ASSEMBLY(STDANDARD)	1
*15B	0667914-00	6494710-00	LOWER HOOK ASSEMBLY(BRONZE)	1
*15C	6447514-00	6449914-00	LOWER HOOK ASSEMBLY(BULLARD)	1
16	0669403-00	0669406-00	LATCH KIT (Incl. Spring & Rivet)	1
17	0633412-00	6441061-04	CAPACITY PLATE	2
18	0149896-00	0149891-00	DRIVE SCREW	4

*Includes Hook, Nut, Latch, Bearing and Roll Pin.

When Replacement Parts Are Needed, Order Only Yale® Factory Engineered Parts

Yale Hoisting Equipment

REPAIR PARTS

Bottom Block Assembly - 1 1/2 Ton, D2 & 2 Ton, D3
 - 1/2 Ton, D2 & 1 Ton, D2

Assemblies 646964200 - 1 1/2 Ton D2
 646983200 - 2 Ton D3
 010154900 - 1/2 Ton D2
 010155900 - 1 Ton D2

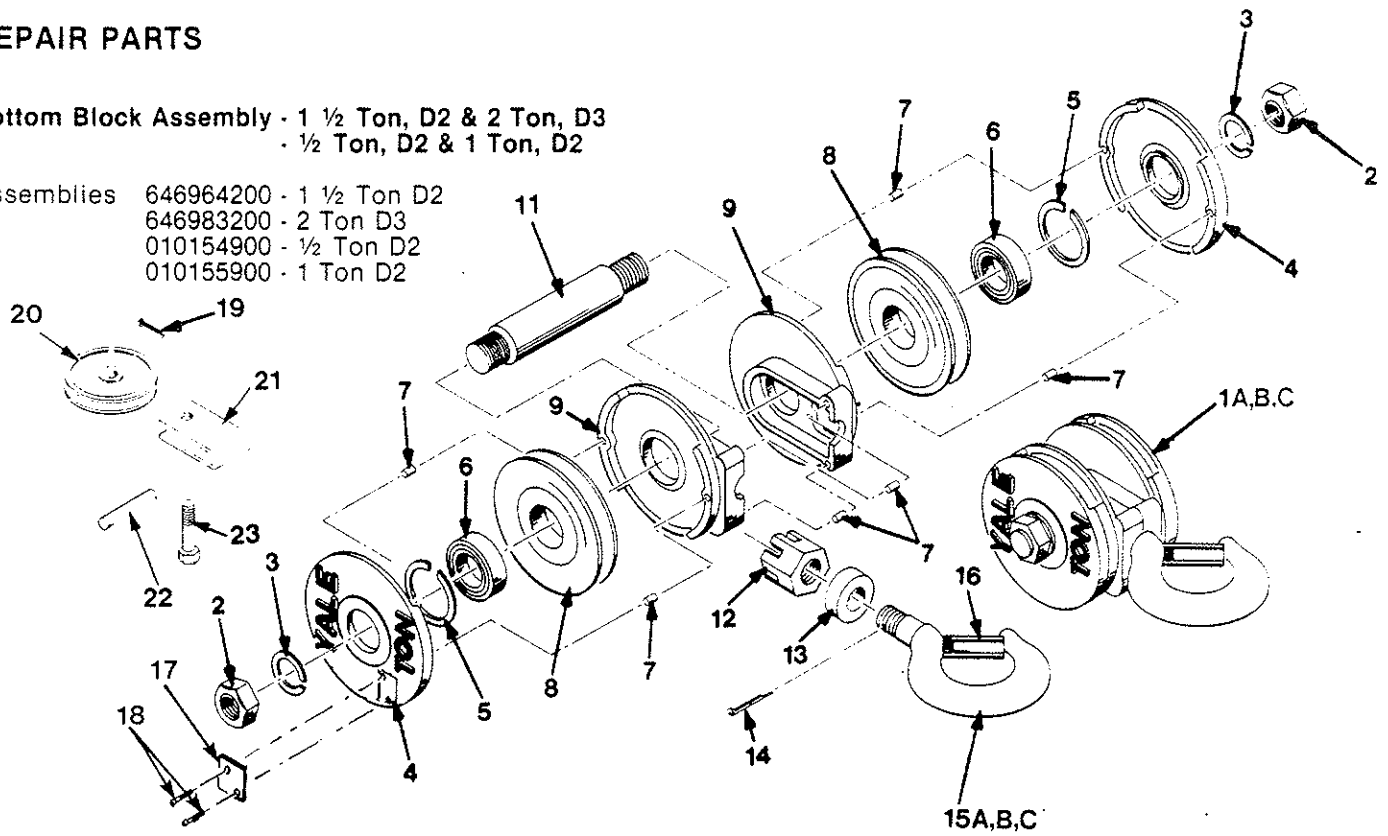

ITEM NBR	PART NUMBER 1/2 TON	PART NUMBER 1 TON	PART NUMBER 1 1/2 TON	PART NUMBER 2 TON	DESCRIPTION	QTY.
1A	0101549-00	0101559-00	6469642-00	6469832-00	BOTTOM BLOCK ASM.(Incl. Item 2 Thru 15A,16 Thru 23)	1
1B	0664837-00	6434412-00	N/A	N/A	BOTTOM BLOCK ASM.(Incl. Item 2 Thru 14,15B,16 thru 23)	1
1C	6434642-00	0662274-00	N/A	N/A	BOTTOM BLOCK ASM.(Incl. Item 2 Thru 14,15C,16 thru 23)	1
2	0149713-00	0149714-00	0149715-00	0149715-00	NUT	2
3	0150268J00	0150270-00	0150296-00	0150296-00	LOCKWASHER	2
4	0101279-00	0101516-00	0666654-00	0666654-00	COVER	2
5	0110019-00	0110017-00	5003439-12	5003439-12	RETAINING RING	2
6	0100807-00	0100808-00	0151283-00	0151283-00	BEARING	2
7	0116526-00	0116526-00	0116526-00	0116526-00	DOWEL PIN	4
8	0109896-00	0109965-00	0109892-00	0109892-00	SHEAVE	2
9	0221082-00	0221081-00	0221089-00	6470573-00	CENTER HALF	2
10	0116531-00	0116531-00	0116531-00	0116531-00	DOWEL PIN	2
11	0109646-00	0109850-00	0109866-00	0109866-00	SHEAVE SHAFT	1
12	0106663-00	0652673-00	0629014-00	0629014-00	SLOTTED NUT	1
13	0151221-00	0151222-00	0220677-00	0220677-00	THRUST BEARING	1
14	0511914-00	0230207-00	0230250-00	0230250-00	ROLL PIN	1
15A	6479090-00	6478970-00	6478990-00	6478990-00	HOOK ASSEMBLY (STD.)	1
15B	6497140-00	6433962-00	0667914-00	0667914-00	HOOK ASSEMBLY (BRONZE)	1
15C	6440243-00	6438533-00	6447514-00	6447514-00	HOOK ASSEMBLY (BULLARD)	1
16	0669402-00	0669402-00	0669403-00	0669403-00	LATCH KIT	1
17	N/A	N/A	6464943-02	0633412-00	CAPACITY PLATE	2
18	N/A	N/A	0149896-00	0149896-00	RIVETS	4
19	N/A	N/A	N/A	0154212-00	COTTER PIN	2
20	N/A	N/A	N/A	6479051-00	EQUALIZER SHEAVE	1
21	N/A	N/A	N/A	6470603-00	YOKE	1
22	N/A	N/A	N/A	6470223-00	SHAFT, EQUALIZER	1
23	N/A	N/A	N/A	6370492-00	YOKE PIN	1

When Replacement Parts Are Needed, Order Only Yale® Factory Engineered Parts

REPAIR PARTS

Bottom Block Assembly - 1/2, 1 & 1 1/2 Ton, 2 Part Single

Assemblies 060573800 - 1/2 Ton
 060573900 - 1 Ton
 646961200 - 1 1/2 Ton

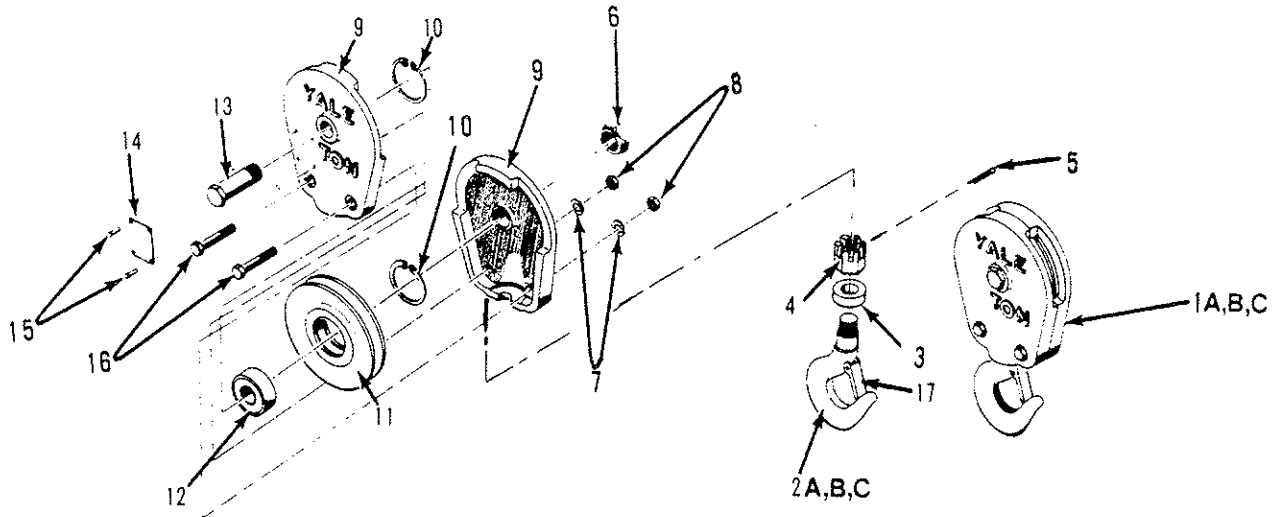

ITEM NUMBER	PART NUMBER 1/2 TON	PART NUMBER 1 TON	PART NUMBER 1 1/2 TON	DESCRIPTION	QTY.
1A	0605738-00	0605739-00	6469612-00	BOTTOM BLOCK ASM.(Incl. Item 2A & 3 Thru 17)	1
1B	0643039-00	6414712-00	N/A	BOTTOM BLOCK ASM.(Incl. Item 2B & 3 Thru 17)	1
1C	6423232-00	6497400-00	N/A	BOTTOM BLOCK ASM.(Incl. Item 2C & 3 Thru 17)	1
*2A	6479090-00	6479100-00	6478990-00	LOWER HOOK ASSEMBLY (STANDARD)	1
*2B	6497140-00	6463772-00	0667914-00	LOWER HOOK ASSEMBLY (BRONZE)	1
*2C	6440243-00	6450734-00	6447514-00	LOWER HOOK ASSEMBLY (BULLARD)	1
3	0100851-00	0100852-00	0220677-00	HOOK BEARING	1
4	0106663-00	0652673-00	0629014-00	SLOTTED NUT	1
5	0154184-00	0154184-00	0230250-00	ROLL PIN	1
6	0106685-00	0106685-00	0149718-00	NUT, 3/4 - 16	1
7	0150262-00	0150262-00	0150266-00	LOCKWASHER	2
8	0149708-00	0149708-00	0149648-00	NUT	2
9	6414394-00	6414394-01	0604063-00	BLOCK HALF	2
10	0110017-00	0110017-00	5003439-10	RETAINING RING	2
11	0109965-00	0109965-00	6431313-00	SHEAVE	1
12	0100808-00	0100808-00	0100788-00	BEARING, SHEAVE	1
13	0107023-00	0107023-00	0109668-00	SHEAVE PIN	1
14	0595021-00	0494028-00	0494042-00	CAPACITY PLATE	2
15	0209149-00	0209149-00	0109149-00	ROUND HEAD SCREW	4
16	0629135-00	0619135-00	0476997-00	SCREW	2
17	0669402-00	0669402-00	0669403-00	LATCH KIT (Incl. Latch, Spring & Rivet)	1

*Includes Hook, Nut, Latch, Bearing and Roll Pin.

When Replacement Parts Are Needed, Order Only Yale® Factory Engineered Parts

Yale Hoisting Equipment

TROLLEY PARTS

6469812-01
 6469812-02
 6469822-01
 6469822-02

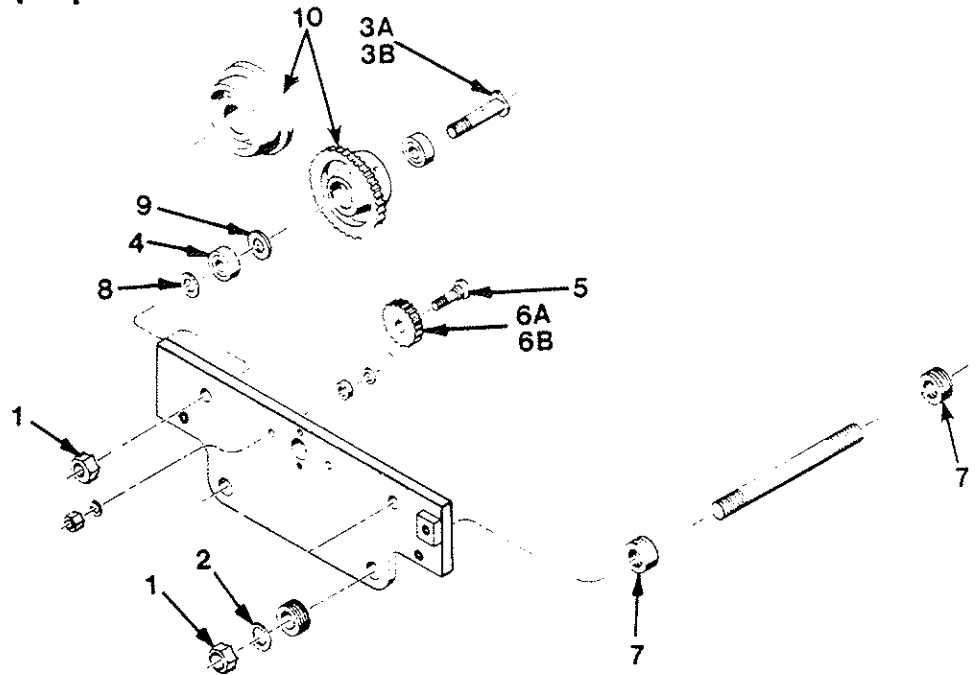

ITEM NO.	PART NUMBER	DESCRIPTION	QTY.
1	0149716-00	NUT	4
2	0150297-00	LOCKWASHER	4
3A	0664038-00	WHEEL AXLE, ASI	4
4A	0541489-00	BEARING (TAPER CONE)	8
4B	0641326-00	BEARING (CUP)	8
4C	6455313-00	SEAL	8
4D	5024531-00	SHIM	8
5	6400811-00	IDLER GEAR STUD (When Used)	12
6A	6456801-00	IDLER GEAR, STEEL (When Used)	2
6B	6456801-00	IDLER GEAR, BRONZE (When Used)	2
7	0114197-00	WASHER	2
8	6447913-06	WASHER	24
10	SEE TABLE 1	WHEEL	4
			AR

Table 1

Tread Type	Wheel Type	Beam Type	Material	Wheel Part Number
Ball	Plain	ASI	Standard	6412133-00
Ball	Geared	ASI	Standard	6412143-00
Ball	Plain	ASI	Bronze	6405663-00
Ball	Geared	ASI	Bronze	6405673-00
Flat	Plain	WF	Standard	6450411-00
Flat	Geared	WF	Standard	6450421-00
Flat	Plain	WF	Bronze	6450431-00
Flat	Geared	WF	Bronze	6450441-00
Flat	Plain	Pat. Track	Standard	6465981-00
Flat	Geared	Pat. Track	Standard	6465991-00
Flat	Plain	Pat. Track	Bronze	6468751-00
Flat	Geared	Pat. Track	Bronze	6468751-00

When Replacement Parts Are Needed, Order Only Yale® Factory Engineered Parts

TROLLEY PARTS

6469802-01
 6469802-02
 6469792-01
 6469792-02

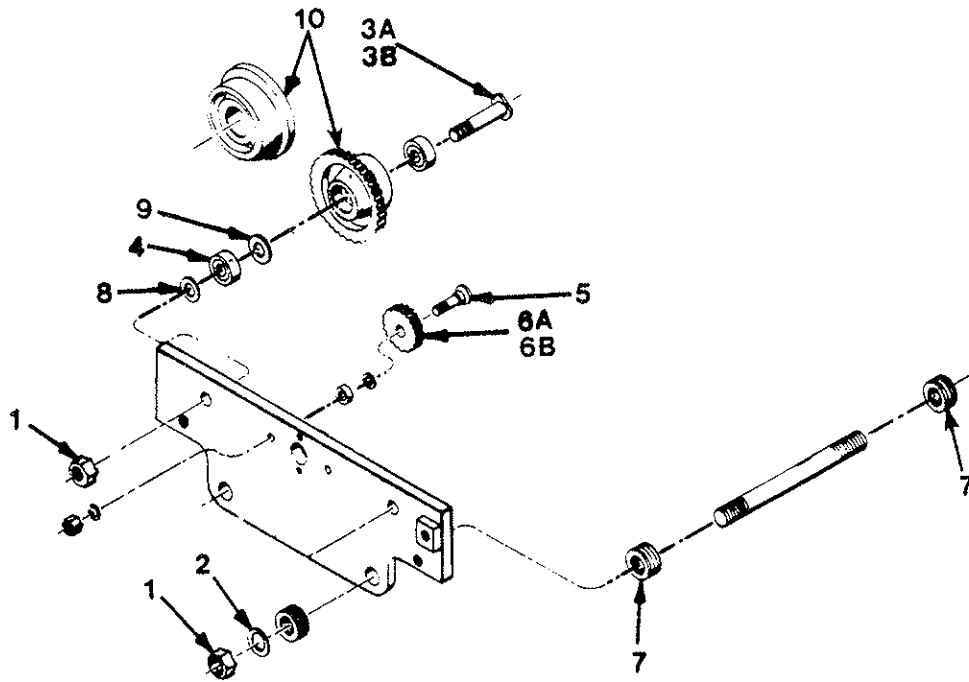

ITEM NO.	PART NUMBER	DESCRIPTION	QTY.
1	0150158-00	NUT	4
2	0150268-00	LOCKWASHER	4
3A	0250576-00	WHEEL AXLE, ASI	4
3B	0650864-00	WHEEL AXLE, PATENTED TRACK	4
4	5003539-07	BALL BEARING	8
5	6400811-00	IDLER GEAR STUD (When Used)	4
6A	6456801-00	IDLER GEAR, STEEL (When Use)	4
6B	6487501-00	IDLER GEAR, BRONZE (When Used)	4
7	0114200-00	WASHER	48
8	0161158-00	WASHER	16
9	6400469-00	RETAINING RING	4
10	SEE TABLE 1	WHEEL	AR

TABLE 1

Tread Type	Wheel Type	Beam Type	Material	Wheel Part Number
Ball	Plain	ASI	Steel	6412103-00
Ball	Geared	ASI	Steel	6412113-00
Ball	Plain	ASI	Bronze	0666220-00
Ball	Geared	ASI	Bronze	5005343-00
Flat	Geared	Pat. Track	Steel	0650863-00
Flat	Plain	Pat. Track	Steel	5011583-00
Flat	Plain	Pat. Track	Bronze	6420413-00
Flat	Geared	Pat. Track	Bronze	6420403-00

When Replacement Parts Are Needed, Order Only Yale® Factory Engineered Parts

Yale Hoisting Equipment

TROLLEY HANDWHEEL GROUP

GT - GEARED TROLLEY
4 7/8" TREAD DIAMETER WHEELS

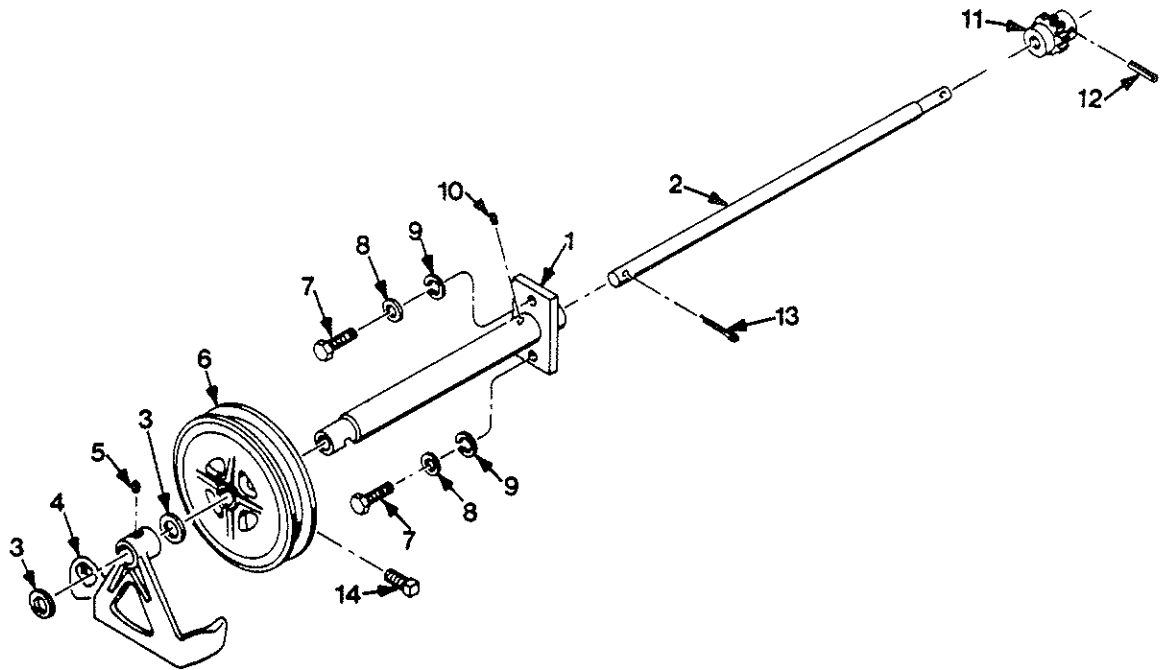

4 7/8" TREAD DIAMETER WHEELS				
ASSEMBLY NUMBER	ITEM 1 EXTENSION	ITEM 2 SHAFT	ITEM 11 PINION	ITEM 12 ROLL PIN
6434722-01	0664454-00	6456491-01	0250202-00	0230207-00

ITEM NUMBER	PART NUMBER	DESCRIPTION	QTY.
3	0250668-00	WASHER	2
4	0588165-00	GUIDE	1
5	0185584-00	FITTING	1
6	0111132-00	HANDWHEEL	1
7	0554850-00	1/2-13 X 1 1/4 HEX HEAD SCREW	2
8	0142209-00	WASHER	2
9	0150266-00	LOCKWASHER	2
10	0227845-00	FITTING	1
11	SEE TABLE	PINION	1
12	SEE TABLE	ROLL PIN	1
13	0381400-00	COTTER PIN	1
14	0388054-00	7/16-14X1 SQUARE HEAD SCREW	1
15	0033730-00	HAND CHAIN (NOT SHOWN) SPECIFY LENGTH	1

When Replacement Parts Are Needed, Order Only Yale® Factory Engineered Parts

REPAIR PARTS

MOTORIZED TROLLEY DRIVE (RT)

Trolley Assembly

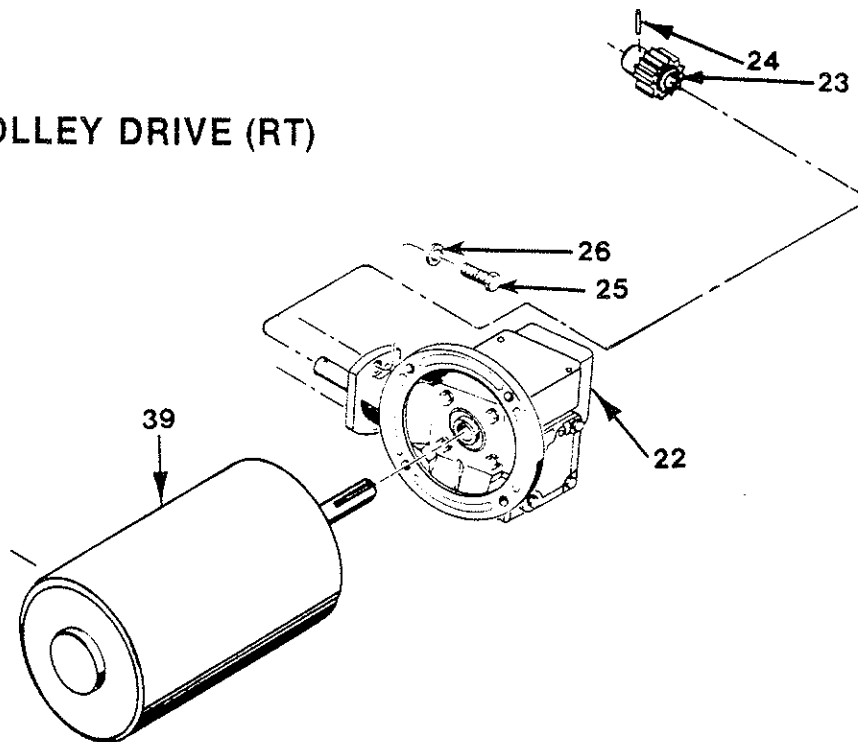

ITEM NBR	PART NUMBER	DESCRIPTION	QTY.
22	SEE TABLE 646700200	GEAR CASE RT MGT. KIT (Incl. Items 23, 24, 25 & 26)	1
23	6462883-00	PINION	1
24	6462973-01	GROOVE PIN	1
25	0554856-00	BOLT	2
26	0150266-00	LOCK WASHER	2
39	.	MOTOR	1
43	0103739-00	LOCKNUT	1
44	6401569-10	WATERTIGHT CONNECTOR	1
45	6431261-81	POWER CORD TO HOIST	7 ft.
46	6401569-18	WATERTIGHT CONNECTOR	1
47	0103740-00	LOCKNUT	1

*When Ordering Motors Give Complete Data On Motor Nameplate.

GEAR TABLE

TRAVEL SPEED (FT/MIN)	GEAR CASE	RATIO
15	6462923-30	30:1
30	6462923-15	15:1
45	6462923-10	10:1
90	6462923-05	5:1

When Replacement Parts Are Needed, Order Only Yale® Factory Engineered Parts

WIRING DIAGRAM

SCHEMATIC

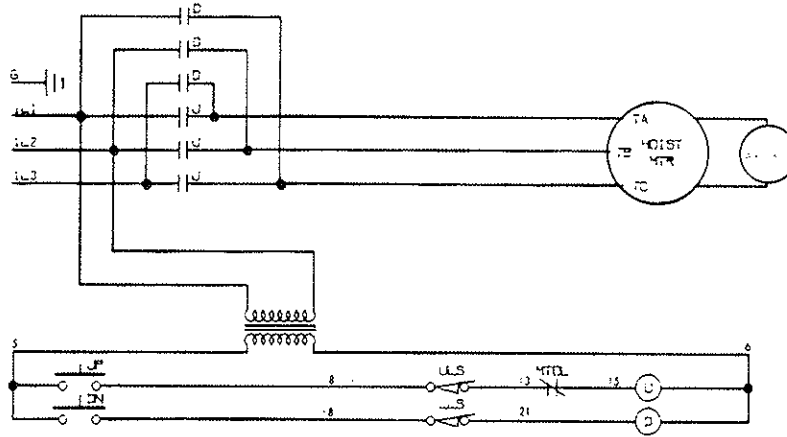

COMPONENT LOCATION

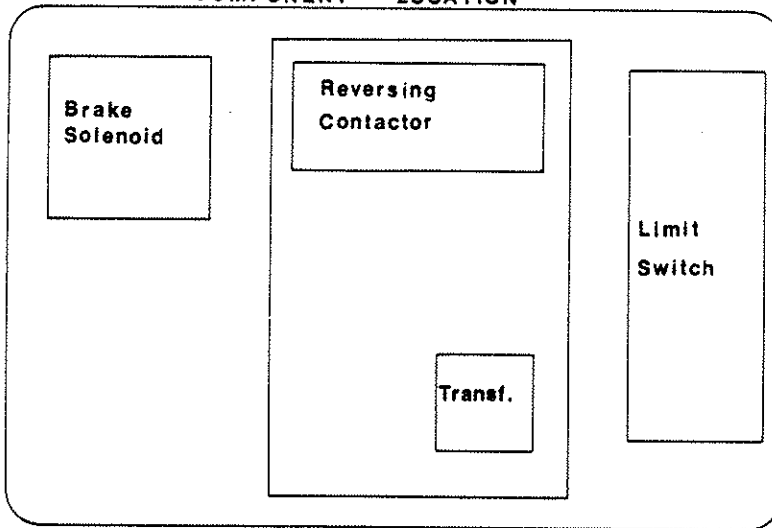

DUAL VOLTAGE MOTOR CONNECTIONS		DUAL VOLTAGE TRANSF. CONNECTIONS	
LOW VOLTAGE	HIGH VOLTAGE	LOW VOLTAGE	HIGH VOLTAGE
TA TB TC T1 T2 T3 T7 T8 T9 B1 B2 T4 T5 T6	TA TB TC T1 T2 T3 T7 T8 T9 B1 B2 T4 T5 T6		

Ltr.	Yr	Mo	Day	Description	WD1007001
------	----	----	-----	-------------	------------------

When Replacement Parts Are Needed, Order Only Yale® Factory Engineered Parts

AUGUST 1984
43
TEW SERIES

WIRING DIAGRAM

THREE PHASE

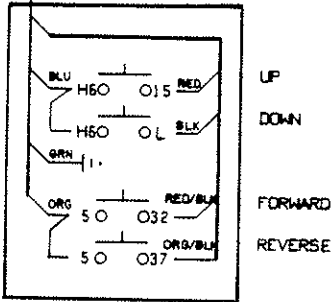
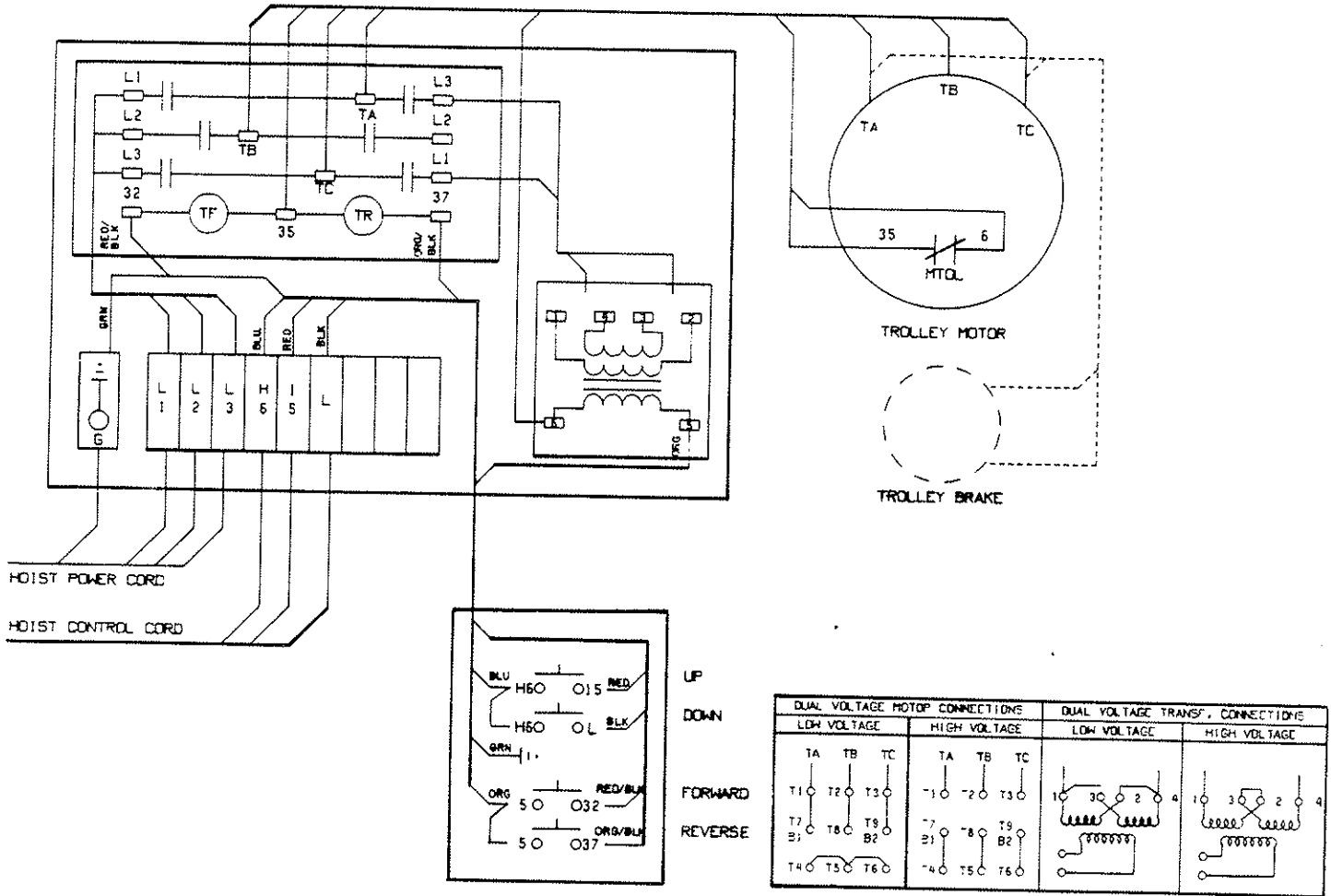

DUAL VOLTAGE MOTOR CONNECTIONS			DUAL VOLTAGE TRANSF. CONNECTIONS								
LOW VOLTAGE			HIGH VOLTAGE			LOW VOLTAGE			HIGH VOLTAGE		
TA	TB	TC	TA	TB	TC						
T1	T2	T3	1	2	3						
T7	T8	T9	7	8	9						
B1	B2	B3	B1	B2	B3						
T4	T5	T6	4	5	6						

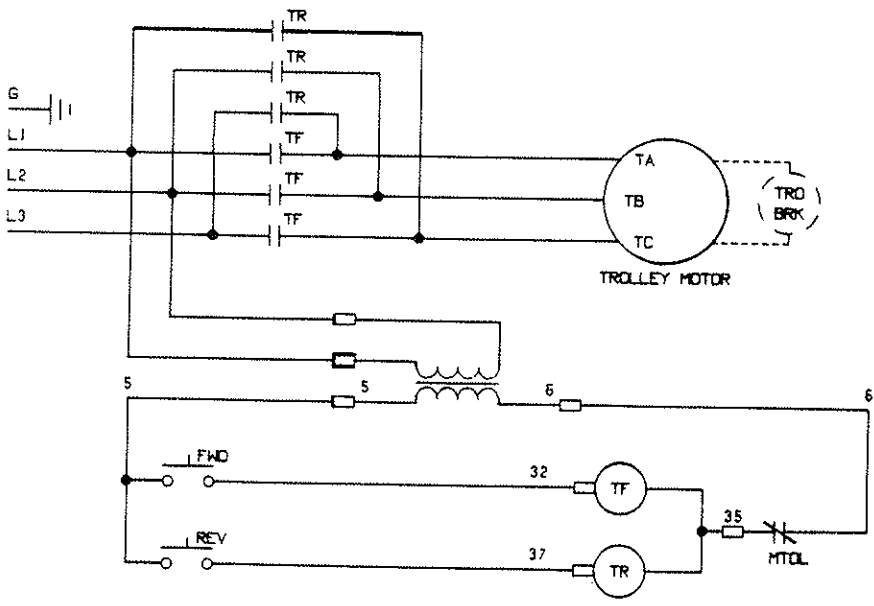

When Replacement Parts Are Needed, Order Only Yale® Factory Engineered Parts

POWERED HOIST INSPECTION CHECK LIST

SEE PREVENTIVE MAINTENANCE SECTION OF INSTRUCTION MANUAL FOR DETAILS.

CHECK ONLY COMPONENTS APPLICABLE FOR SPECIFIC EQUIPMENT AND INSPECTION TYPE.

HOIST MODEL _____

HOIST S/N _____

HOOKS	YES	NO	CABLE	YES	NO	CHAINS	YES	NO
HARDWARE LOOSE	<input type="checkbox"/>	<input type="radio"/>	BROKEN WIRES AT ENDS	<input type="checkbox"/>	<input type="radio"/>	BINDING	<input type="checkbox"/>	<input type="radio"/>
CRACKS	<input type="checkbox"/>	<input type="radio"/>	BROKEN WIRES EXCESSIVE	<input type="checkbox"/>	<input type="radio"/>	CRACKED	<input type="checkbox"/>	<input type="radio"/>
EXCESSIVE WEAR	<input type="checkbox"/>	<input type="radio"/>	EXCESSIVE WEAR	<input type="checkbox"/>	<input type="radio"/>	TWISTED	<input type="checkbox"/>	<input type="radio"/>
BENT	<input type="checkbox"/>	<input type="radio"/>	KINKED OR DISTORTED	<input type="checkbox"/>	<input type="radio"/>	DISTORTED	<input type="checkbox"/>	<input type="radio"/>
SPREADING	<input type="checkbox"/>	<input type="radio"/>	CORROSION	<input type="checkbox"/>	<input type="radio"/>	CORRODED	<input type="checkbox"/>	<input type="radio"/>
FREELY ROTATE	<input type="radio"/>	<input type="checkbox"/>	HEAT DAMAGED	<input type="checkbox"/>	<input type="radio"/>	EXCESSIVE WEAR	<input type="checkbox"/>	<input type="radio"/>
LATCH DAMAGED	<input type="checkbox"/>	<input type="radio"/>				WORN CHAIN GUIDES	<input type="checkbox"/>	<input type="radio"/>
						POCKET WHEELS WORN	<input type="checkbox"/>	<input type="radio"/>
BRAKES			WIRING			DRUM & SHEAVES		
MOTOR BRAKE WORN OR NOT OPERATING	<input type="checkbox"/>	<input type="radio"/>	LOOSE CONNECTIONS	<input type="checkbox"/>	<input type="radio"/>	WORN EXCESSIVELY	<input type="checkbox"/>	<input type="radio"/>
EXCESSIVE LOADBRAKE DRIFT OR BLACKLASH	<input type="checkbox"/>	<input type="radio"/>	FRAYED	<input type="checkbox"/>	<input type="radio"/>	CRACKED OR SCORED	<input type="checkbox"/>	<input type="radio"/>
EXCESSIVE DISC WEAR	<input type="checkbox"/>	<input type="radio"/>	DAMAGED	<input type="checkbox"/>	<input type="radio"/>			
			PROPER GROUNDING	<input type="radio"/>	<input type="checkbox"/>			
LIMIT SWITCHES			LOAD LIMITING DEVICE			COLLECTORS		
OPERATING PROPERLY	<input type="radio"/>	<input type="checkbox"/>	OPERATING PROPERLY	<input type="radio"/>	<input type="checkbox"/>	BINDING	<input type="checkbox"/>	<input type="radio"/>
						EXCESSIVE WEAR	<input type="checkbox"/>	<input type="radio"/>
HOUSING			OPERATION CONTROLS			LUBRICATION		
DISTORTED	<input type="checkbox"/>	<input type="radio"/>	CONTACTOR PITTING	<input type="checkbox"/>	<input type="radio"/>	ALL POINTS LUBRICATED AS GIVEN IN LUB CHART	<input type="radio"/>	<input type="checkbox"/>
CRACKS	<input type="checkbox"/>	<input type="radio"/>	OPERATING PROPERLY	<input type="radio"/>	<input type="checkbox"/>	OIL DARK OR LOW	<input type="checkbox"/>	<input type="radio"/>
LOOSE HARDWARE	<input type="checkbox"/>	<input type="radio"/>	DAMAGED PUSH BUTTON	<input type="checkbox"/>	<input type="radio"/>	OIL LEAKS	<input type="checkbox"/>	<input type="radio"/>
BEARING NOISE	<input type="checkbox"/>	<input type="radio"/>	HOUSING	<input type="checkbox"/>	<input type="radio"/>			
SUPPORTING STRUCTURE			AIR SYSTEM			WARNING LABELS		
CONTINUED ABILITY TO SUPPORT IMPOSED LOADS	<input type="radio"/>	<input type="checkbox"/>	LEAKING	<input type="checkbox"/>	<input type="radio"/>	MISSING	<input type="checkbox"/>	<input type="radio"/>
WORN OR DISTORTED TROLLEY PARTS	<input type="checkbox"/>	<input type="radio"/>	LOOSE CONNECTIONS	<input type="checkbox"/>	<input type="radio"/>	ILLEGIBLE	<input type="checkbox"/>	<input type="radio"/>
			BROKEN CONTROL PENDANT	<input type="checkbox"/>	<input type="radio"/>			

NOTE: IF ANY (☐) IS CHECKED DO NOT OPERATE THE HOIST UNTIL REPAIRS HAVE BEEN MADE.

REMARKS AND REPAIRS MADE _____

SIGNATURE _____ DATE _____ CLOCK NUMBER _____

POWERED HOIST INSPECTION CHECK LIST

SEE PREVENTIVE MAINTENANCE SECTION OF INSTRUCTION MANUAL FOR DETAILS.

CHECK ONLY COMPONENTS APPLICABLE FOR SPECIFIC EQUIPMENT AND INSPECTION TYPE.

HOIST MODEL _____

HOIST S/N _____

HOOKS	YES	NO	CABLE	YES	NO	CHAINS	YES	NO
HARDWARE LOOSE	<input type="checkbox"/>	<input type="checkbox"/>	BROKEN WIRES AT ENDS	<input type="checkbox"/>	<input type="checkbox"/>	BINDING	<input type="checkbox"/>	<input type="checkbox"/>
CRACKS	<input type="checkbox"/>	<input type="checkbox"/>	BROKEN WIRES EXCESSIVE	<input type="checkbox"/>	<input type="checkbox"/>	CRACKED	<input type="checkbox"/>	<input type="checkbox"/>
EXCESSIVE WEAR	<input type="checkbox"/>	<input type="checkbox"/>	EXCESSIVE WEAR	<input type="checkbox"/>	<input type="checkbox"/>	TWISTED	<input type="checkbox"/>	<input type="checkbox"/>
BENT	<input type="checkbox"/>	<input type="checkbox"/>	KINKED OR DISTORTED	<input type="checkbox"/>	<input type="checkbox"/>	DISTORTED	<input type="checkbox"/>	<input type="checkbox"/>
SPREADING	<input type="checkbox"/>	<input type="checkbox"/>	CORROSION	<input type="checkbox"/>	<input type="checkbox"/>	CORRODED	<input type="checkbox"/>	<input type="checkbox"/>
FREELY ROTATE	<input type="checkbox"/>	<input type="checkbox"/>	HEAT DAMAGED	<input type="checkbox"/>	<input type="checkbox"/>	EXCESSIVE WEAR	<input type="checkbox"/>	<input type="checkbox"/>
LATCH DAMAGED	<input type="checkbox"/>	<input type="checkbox"/>				WORN CHAIN GUIDES	<input type="checkbox"/>	<input type="checkbox"/>
						POCKET WHEELS WORN	<input type="checkbox"/>	<input type="checkbox"/>
BRAKES			WIRING			DRUM & SHEAVES		
MOTOR BRAKE WORN OR NOT OPERATING	<input type="checkbox"/>	<input type="checkbox"/>	LOOSE CONNECTIONS	<input type="checkbox"/>	<input type="checkbox"/>	WORN EXCESSIVELY	<input type="checkbox"/>	<input type="checkbox"/>
EXCESSIVE LOADBRAKE DRIFT OR BLACKLASH	<input type="checkbox"/>	<input type="checkbox"/>	FRAYED	<input type="checkbox"/>	<input type="checkbox"/>	CRACKED OR SCORED	<input type="checkbox"/>	<input type="checkbox"/>
EXCESSIVE DISC WEAR	<input type="checkbox"/>	<input type="checkbox"/>	DAMAGED	<input type="checkbox"/>	<input type="checkbox"/>			
			PROPER GROUNDING	<input type="checkbox"/>	<input type="checkbox"/>			
LIMIT SWITCHES			LOAD LIMITING DEVICE			COLLECTORS		
OPERATING PROPERLY	<input type="checkbox"/>	<input type="checkbox"/>	OPERATING PROPERLY	<input type="checkbox"/>	<input type="checkbox"/>	BINDING	<input type="checkbox"/>	<input type="checkbox"/>
						EXCESSIVE WEAR	<input type="checkbox"/>	<input type="checkbox"/>
HOUSING			OPERATION CONTROLS			LUBRICATION		
DISTORTED	<input type="checkbox"/>	<input type="checkbox"/>	CONTACTOR PITTING	<input type="checkbox"/>	<input type="checkbox"/>	ALL POINTS LUBRICATED AS GIVEN IN LUB CHART	<input type="checkbox"/>	<input type="checkbox"/>
CRACKS	<input type="checkbox"/>	<input type="checkbox"/>	OPERATING PROPERLY	<input type="checkbox"/>	<input type="checkbox"/>	OIL DARK OR LOW	<input type="checkbox"/>	<input type="checkbox"/>
LOOSE HARDWARE	<input type="checkbox"/>	<input type="checkbox"/>	DAMAGED PUSH BUTTON	<input type="checkbox"/>	<input type="checkbox"/>	OIL LEAKS	<input type="checkbox"/>	<input type="checkbox"/>
BEARING NOISE	<input type="checkbox"/>	<input type="checkbox"/>	HOUSING	<input type="checkbox"/>	<input type="checkbox"/>			
SUPPORTING STRUCTURE			AIR SYSTEM			WARNING LABELS		
CONTINUED ABILITY TO SUPPORT IMPOSED LOADS	<input type="checkbox"/>	<input type="checkbox"/>	LEAKING	<input type="checkbox"/>	<input type="checkbox"/>	MISSING	<input type="checkbox"/>	<input type="checkbox"/>
WORN OR DISTORTED TROLLEY PARTS	<input type="checkbox"/>	<input type="checkbox"/>	LOOSE CONNECTIONS	<input type="checkbox"/>	<input type="checkbox"/>	ILLEGIBLE	<input type="checkbox"/>	<input type="checkbox"/>
			BROKEN CONTROL PENDANT	<input type="checkbox"/>	<input type="checkbox"/>			

NOTE: IF ANY (☐) IS CHECKED DO NOT OPERATE THE HOIST UNTIL REPAIRS HAVE BEEN MADE.

REMARKS AND REPAIRS MADE _____

SIGNATURE _____ DATE _____ CLOCK NUMBER _____

Warranty

Every hoist is thoroughly inspected and tested prior to shipment from the factory. Should any problems develop, return the complete hoist prepaid to your nearest Yale Hoists Authorized Warranty Repair Station.

This warranty does not apply where: (1) deterioration is caused by normal wear, abuse, improper or inadequate power supply, eccentric or side loading, overloading, chemical or abrasive actions, improper maintenance or excessive heat; (2) problems resulted from repairs, modifications or alterations made by

persons other than factory or Duff-Norton personnel; (3) the hoist has been abused or damaged as a result of an accident; (4) repair parts or accessories other than those supplied by Duff Norton are used on the hoist. Equipment and accessories not of the seller's manufacture are warranted only to the extent that they are warranted by the manufacturer. EXCEPT AS STATED HEREIN, DUFF-NORTON MAKES NO OTHER WARRANTIES, EXPRESS OR IMPLIED, INCLUDING WARRANTIES OF MERCHANTABILITY AND FITNESS FOR A PARTICULAR PURPOSE.

Improvements:

Yale Hoists is constantly striving to improve its product. Changes in design and improvements will be made whenever manufacturer believes the efficiency of the product will be improved without incurring any obligation to incorporate such improvements in any products which have been shipped or are in service.

Important Notice:

Use of chain, wire rope or replacement parts other than as supplied as original equipment on Yale hoists may lead to dangerous operation. Accordingly, Yale Hoists cannot be responsible in such cases and our warranty will be voided.

For more information write Yale Hoists, Forrest City, Arkansas 72335.



Yale Hoists
Highway 1 North
P.O. Box 1000
Forrest City, Arkansas 72335
Customer Service (800) 999-6318
FAX (800) 766-0223

